

Dual N-Channel Enhancement Mode Power MOSFET

Description

The MXN2508 uses advanced trench technology to provide excellent $R_{DS(ON)}$, low gate charge and operation with gate voltages as low as 2.5V. This device is suitable for use as a load switch or in PWM applications. It is ESD protected.

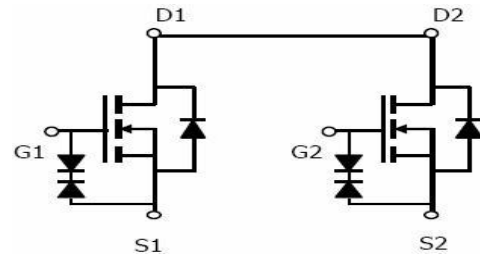

Schematic diagram

General Features

- ◆ $V_{DS} = 20V$, $I_D = 8A$
 - @ $V_{GS} = 4.5V$ $R_{DS(ON)}$ (Typ.) = 14m Ω
 - @ $V_{GS} = 4.2V$ $R_{DS(ON)}$ (Typ.) = 14.4m Ω
 - @ $V_{GS} = 3.8V$ $R_{DS(ON)}$ (Typ.) = 15.6m Ω
 - @ $V_{GS} = 2.5V$ $R_{DS(ON)}$ (Typ.) = 19m Ω
- ◆ ESD Rating: 2000V HBM
- ◆ Advanced trench MOSFET process technology
- ◆ Ultra low on-resistance with low gate charge
- ◆ New Thermally Enhanced DFN2X5-6L Package

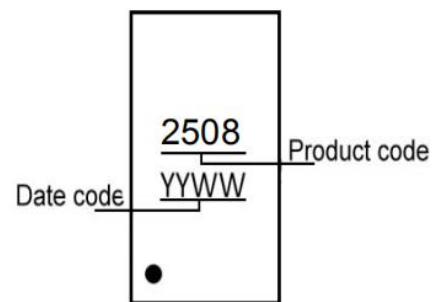

Marking Description

Application

- ◆ PWM applications
- ◆ Load switch
- ◆ battery charge in cellular handset

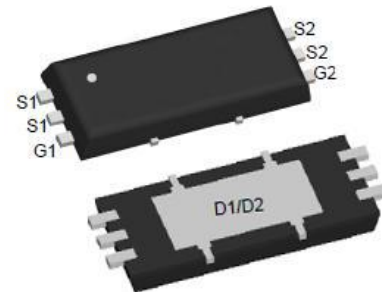

DFN2x5-6L Pin definition and Top / Bottom View

Absolute Maximum Ratings ($T_A = 25^\circ C$ unless otherwise noted)

Parameter	Symbol	Limit	Unit
Drain-Source Voltage	V_{DS}	20	V
Gate-Source Voltage	V_{GS}	± 12	V
Drain Current-Continuous	I_D	8	A
Drain Current-Pulsed (Note 1)	I_{DM}	32	A
Maximum Power Dissipation	P_D	1.7	W
Operating Junction and Storage Temperature Range	T_J, T_{STG}	-55 To 150	$^\circ C$

Electrical Characteristics (TA=25°C unless otherwise noted)

Parameter	Symbol	Condition	Min	Typ	Max	Unit
Off Characteristics						
Drain-Source Breakdown Voltage	BV_{DSS}	$V_{GS}=0V, I_D=250\mu A$	20	-	-	V
Zero Gate Voltage Drain Current	I_{DSS}	$V_{DS}=20V, V_{GS}=0V$	-	-	1	μA
Gate-Body Leakage Current	I_{GSS}	$V_{GS}=\pm 10V, V_{DS}=0V$	-	-	± 10	μA
On Characteristics (Note 3)						
Gate Threshold Voltage	$V_{GS(th)}$	$V_{DS}=V_{GS}, I_D=250\mu A$	0.45	0.7	0.95	V
Drain-Source On-State Resistance	$R_{DS(on)}$	$V_{GS}=4.5V, I_D=6.5A$	12	14	16	m Ω
		$V_{GS}=4.2V, I_D=6.5A$	12.5	14.4	17	m Ω
		$V_{GS}=3.8V, I_D=5.5A$	13	15.6	18	m Ω
		$V_{GS}=2.5V, I_D=5.5A$	17	19	22	m Ω
Forward Transconductance	g_{FS}	$V_{DS}=5V, I_D=7A$	-	20	-	S
Dynamic Characteristics (Note4)						
Input Capacitance	C_{iss}	$V_{DS}=10V, V_{GS}=0V$ $F=1.0MHz$	-	1150	-	PF
Output Capacitance	C_{oss}		-	185	-	PF
Reverse Transfer Capacitance	C_{rss}		-	145	-	PF
Switching Characteristics (Note 4)						
Turn-on Delay Time	$t_{d(on)}$	$V_{DD}=10V, R_L=1.35\Omega$ $V_{GS}=5V, R_{GEN}=3\Omega$	-	6	-	nS
Turn-on Rise Time	t_r		-	13	-	nS
Turn-Off Delay Time	$t_{d(off)}$		-	52	-	nS
Turn-Off Fall Time	t_f		-	16	-	nS
Total Gate Charge	Q_g	$V_{DS}=10V, I_D=7A,$ $V_{GS}=4.5V$	-	15	-	nC
Gate-Source Charge	Q_{gs}		-	0.8	-	nC
Gate-Drain Charge	Q_{gd}		-	3.2	-	nC
Drain-Source Diode Characteristics						
Diode Forward Voltage (Note 3)	V_{SD}	$V_{GS}=0V, I_S=1A$	-	-	1.2	V
Diode Forward Current (Note 2)	I_S		-	-	7	A

Notes:

- surface mounted on FR4 board, $t \leq 10sec$
- pulse test: pulse width $\leq 300\mu s$, duty $\leq 2\%$
- guaranteed by design, not subject to production testing

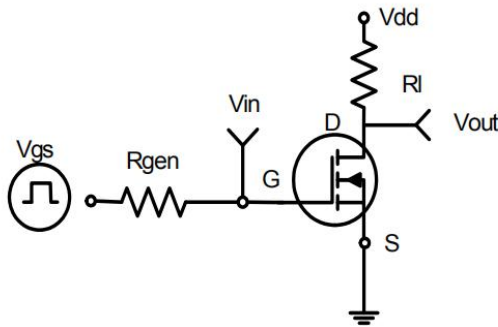
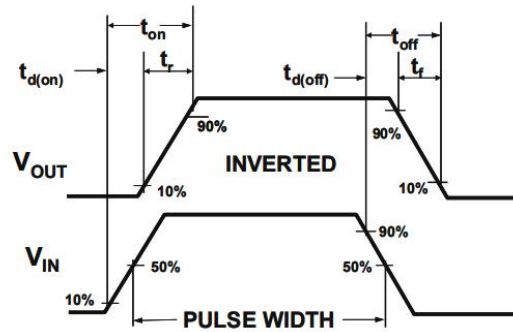
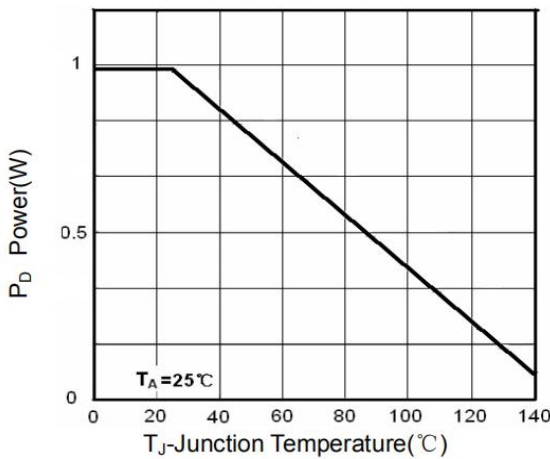
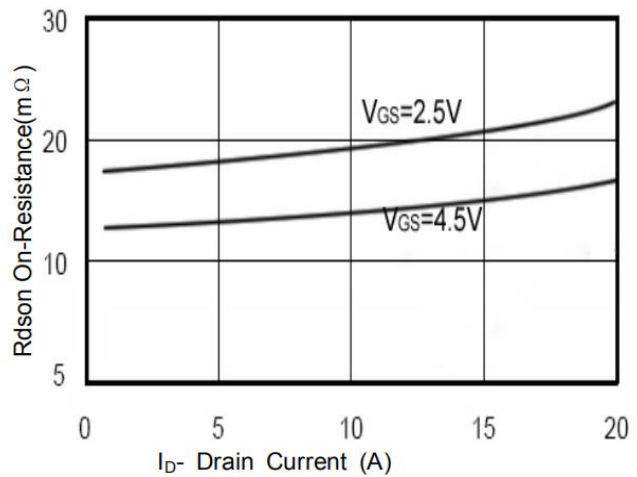
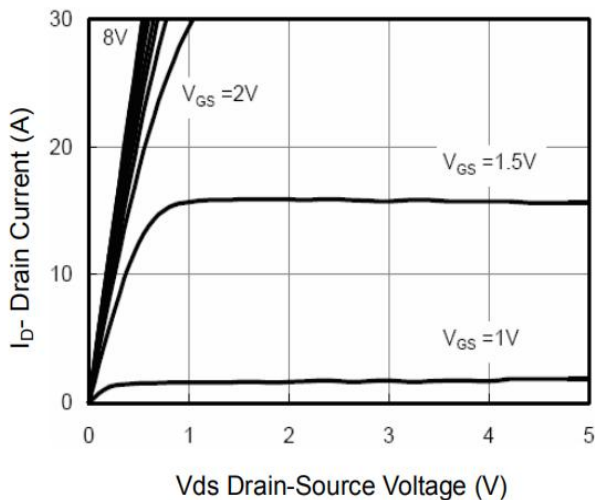
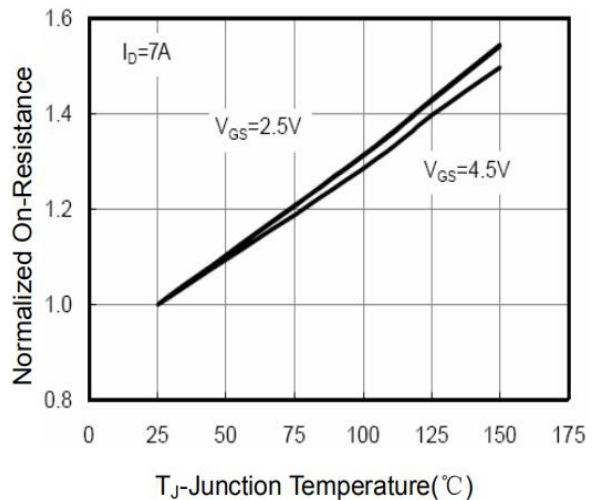
TYPICAL ELECTRICAL AND THERMAL CHARACTERISTICS

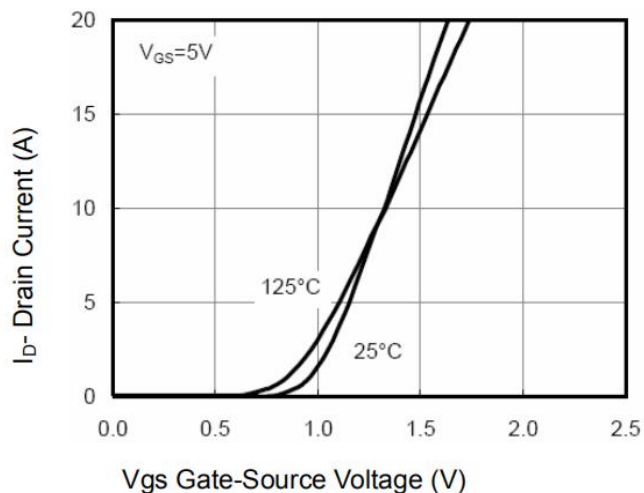
Figure 1: Switching Test Circuit

Figure 2: Switching Waveforms

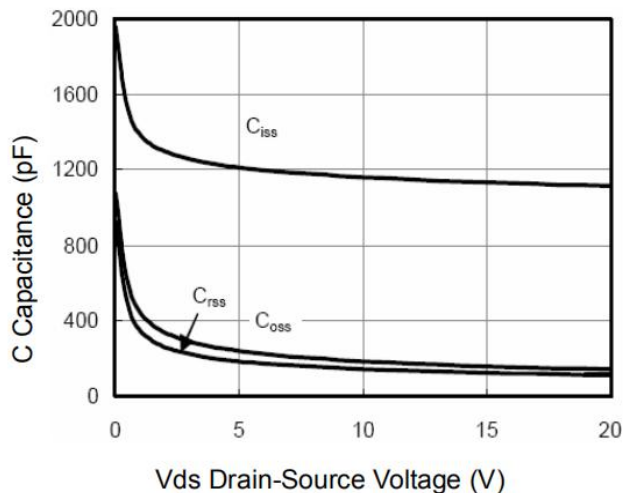
Figure 3 Power Dissipation

Figure 4 Drain-Source On-Resistance

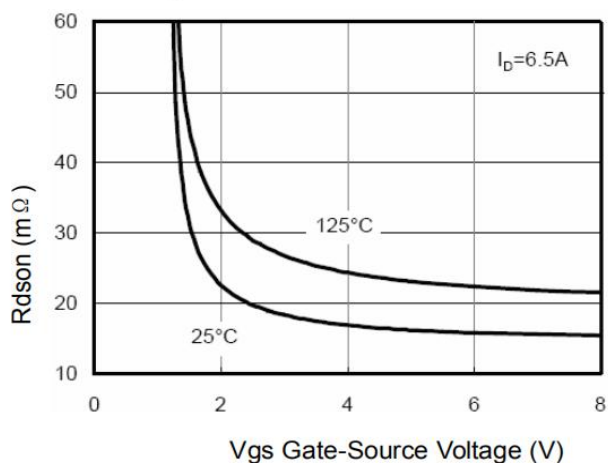
Figure 5 Output CHARACTERISTICS

Figure 6 Drain-Source On-Resistance



Vgs Gate-Source Voltage (V)
Figure 7 Transfer Characteristics



Vds Drain-Source Voltage (V)
Figure 8 Capacitance vs Vds



Vgs Gate-Source Voltage (V)
Figure 9 Rds(on) vs Vgs

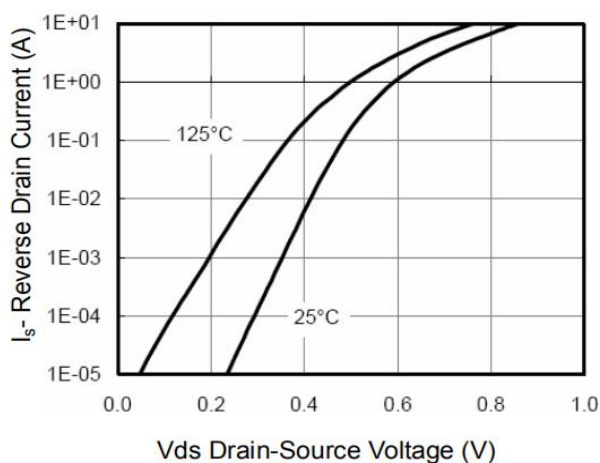

Vds Drain-Source Voltage (V)
Figure 10 Capacitance vs Vds

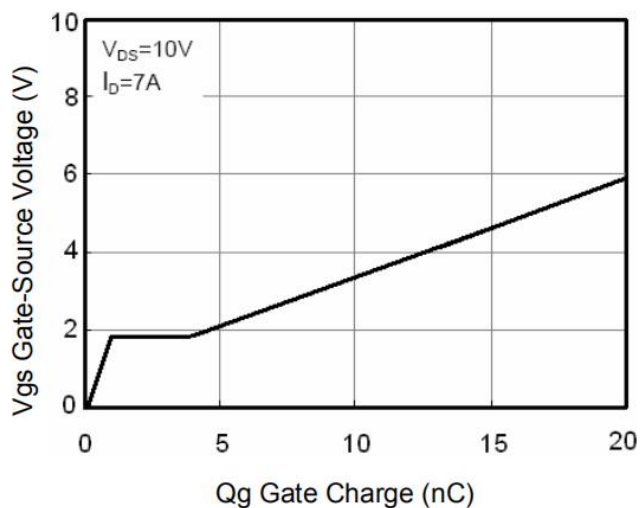

Qg Gate Charge (nC)
Figure 11 Gate Charge

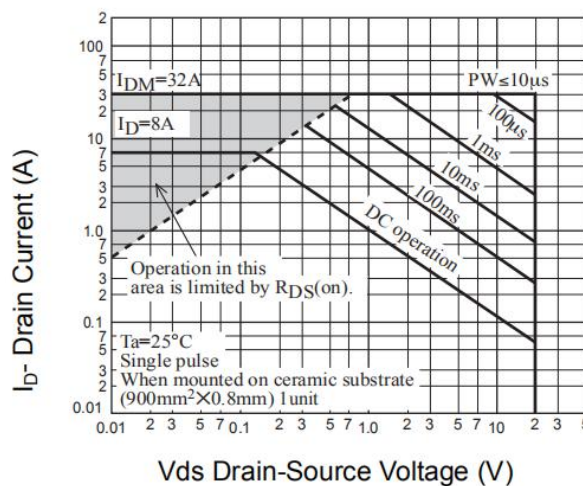

Vds Drain-Source Voltage (V)
Figure 12 Safe Operation Area

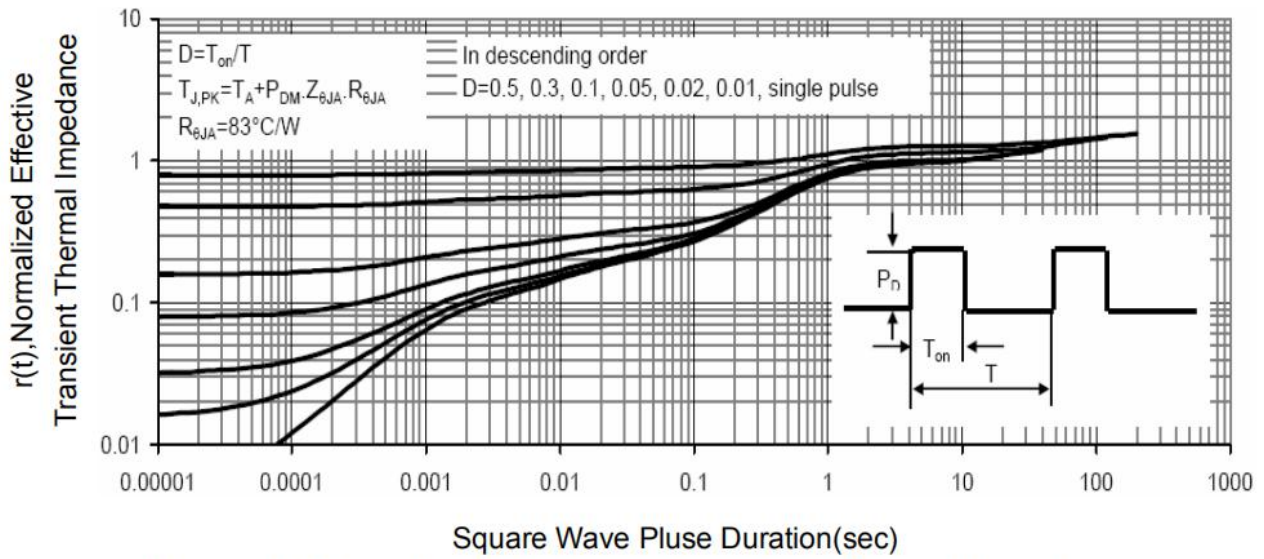
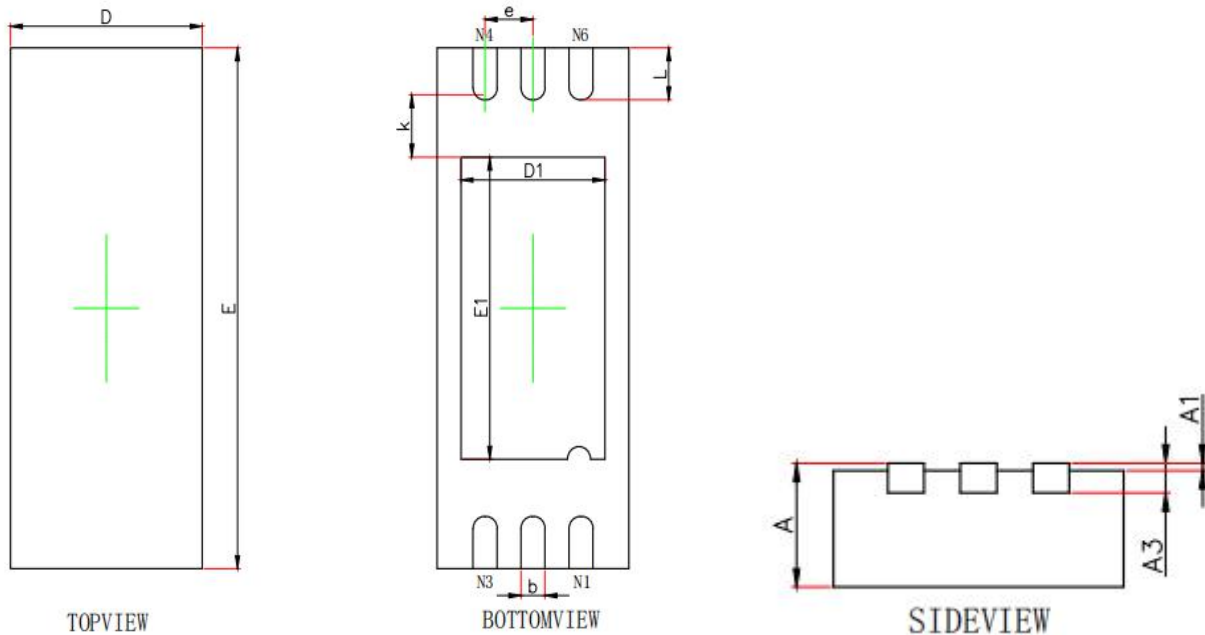

Figure 13 Normalized Maximum Transient Thermal Impedance

DFN2X5-6L PACKAGE OUTLINE DIMENSIONS

DFNWB2×5-6L (P0. 50T0. 75/0. 85) PACKAGE OUTLINE DIMENSIONS



Symbol	Dimensions In Millimeters		Dimensions In Inches	
	Min.	Max.	Min.	Max.
A	0.700/0.800	0.800/0.900	0.028/0.031	0.031/0.035
A1	0.000	0.050	0.000	0.002
A3	0.203REF.		0.008REF.	
D	1.924	2.076	0.076	0.082
E	4.924	5.076	0.194	0.200
D1	1.400	1.600	0.055	0.063
E1	2.800	3.000	0.110	0.118
k	0.200MIN.		0.008MIN.	
b	0.200	0.300	0.008	0.012
e	0.500TYP.		0.020TYP.	
L	0.374	0.526	0.015	0.021