

**N-Channel Enhancement Mode Power MOSFET**

The MX8205L uses advanced trench technology to provide excellent  $R_{DS(ON)}$ , low gate charge and operation with gate voltages as low as 2.5V. This device is suitable for use as a Battery protection or in other Switching applications.

**General Features**

- ◆  $V_{DS} = 20V, I_D = 6A$
- ◆  $R_{DS(ON)} (Typ.) = 16m\Omega @ V_{GS} = 4.5V$
- ◆  $R_{DS(ON)} (Typ.) = 17m\Omega @ V_{GS} = 3.8V$
- ◆  $R_{DS(ON)} (Typ.) = 21m\Omega @ V_{GS} = 2.5V$
- ◆ High Power and current handling capability
- ◆ Lead free product is acquired
- ◆ Surface Mount Package

**Applicatio**

Battery protection  
Load switch  
Power management

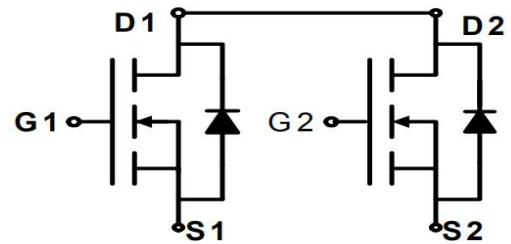
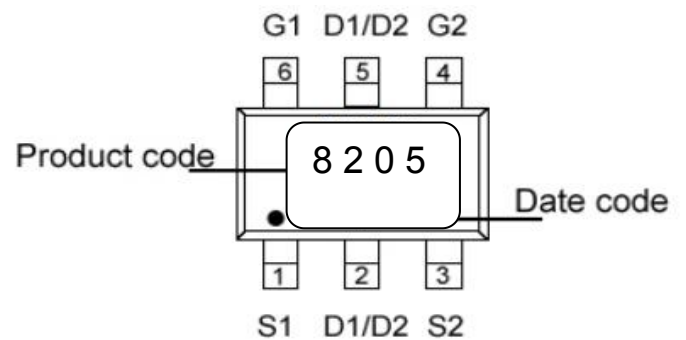
**Schematic diagram**

**Marking and pin assignment**

**SOT-23-6 (TOP VIEW)**
**ASoI Absolute Maximum Ratings (TA=25°C unless otherwise noted)**

Parameter	Symbol	Limit	Unit
Drain-Source Voltage	$V_{DS}$	20	V
Gate-Source Voltage	$V_{GS}$	$\pm 12$	V
Drain Current-Continuous	$I_D$	6	A
Drain Current-Pulsed (Note 1)	$I_{DM}$	24	A
Maximum Power Dissipation	$P_D$	1.25	W
Operating Junction and Storage Temperature Range	$T_J, T_{STG}$	-55 To 150	°C

**Thermal Characteristic**

Thermal Resistance, Junction-to-Ambient (Note 2)	$R_{\theta JA}$	83	$^{\circ}C/W$
--	-----------------	----	---------------

**Electrical Characteristics (TA=25 $^{\circ}C$  unless otherwise noted)**

Parameter	Symbol	Condition	Min	Typ	Max	Unit
<b>Off Characteristics</b>						
Drain-Source Breakdown Voltage	$BV_{DSS}$	$V_{GS}=0V, I_D=250\mu A$	20	21	-	V
Zero Gate Voltage Drain Current	$I_{DSS}$	$V_{DS}=19.5V, V_{GS}=0V$	-	-	1	$\mu A$
Gate-Body Leakage Current	$I_{GSS}$	$V_{GS}=\pm 10V, V_{DS}=0V$	-	-	$\pm 100$	nA
<b>On Characteristics (Note 3)</b>						
Gate Threshold Voltage	$V_{GS(th)}$	$V_{DS}=V_{GS}, I_D=250\mu A$	0.4	0.65	1	V
Drain-Source On-State Resistance	$R_{DS(on)}$	$V_{GS}=4.5V, I_D=4.5A$	-	16	20	$m\Omega$
		$V_{GS}=3.8V, I_D=4A$	-	17	21	
		$V_{GS}=2.5V, I_D=3.5A$	-	21	28	$m\Omega$
Forward Transconductance	$g_{FS}$	$V_{DS}=5V, I_D=4.5A$	-	10	-	S
<b>Dynamic Characteristics (Note4)</b>						
Input Capacitance	$C_{iss}$	$V_{DS}=8V, V_{GS}=0V,$ $F=1.0MHz$	-	600	-	PF
Output Capacitance	$C_{oss}$		-	330	-	PF
Reverse Transfer Capacitance	$C_{rss}$		-	140	-	PF
<b>Switching Characteristics (Note 4)</b>						
Turn-on Delay Time	$t_{d(on)}$	$V_{DD}=10V, I_D=1A,$ $V_{GS}=4.5V, R_G=6\Omega$	-	10	20	nS
Turn-on Rise Time	$t_r$		-	11	25	nS
Turn-Off Delay Time	$t_{d(off)}$		-	35	70	nS
Turn-Off Fall Time	$t_f$		-	30	60	nS
Total Gate Charge	$Q_g$	$V_{DS}=10V, I_D=6A,$ $V_{GS}=4.5V$	-	10	15	nC
Gate-Source Charge	$Q_{gs}$		-	2.3	-	nC
Gate-Drain Charge	$Q_{gd}$		-	1.5	-	nC
<b>Drain-Source Diode Characteristics</b>						
Diode Forward Voltage (Note 3)	$V_{SD}$	$V_{GS}=0V, I_S=1.7A$	-	0.75	1.2	V
Diode Forward Current (Note 2)	$I_S$		-	-	1.7	A

**Notes:**

1. Repetitive Rating: Pulse width limited by maximum junction temperature.
2. Surface Mounted on FR4 Board,  $t \leq 10$  sec.
3. Pulse Test: Pulse Width  $\leq 300\mu s$ , Duty Cycle  $\leq 2\%$ .

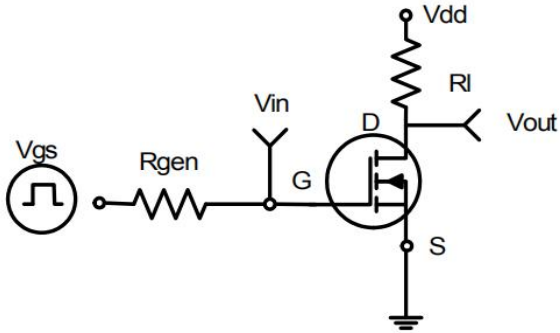
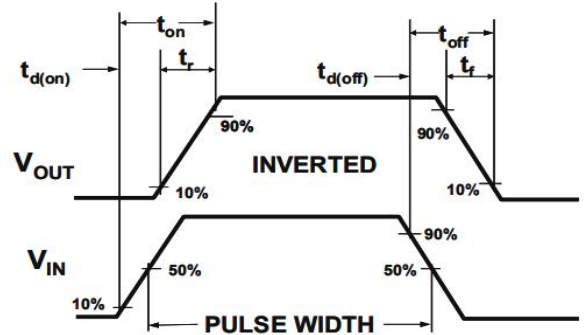
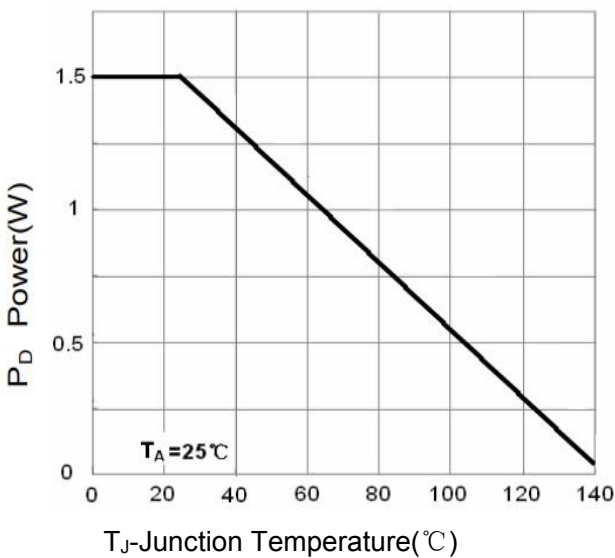
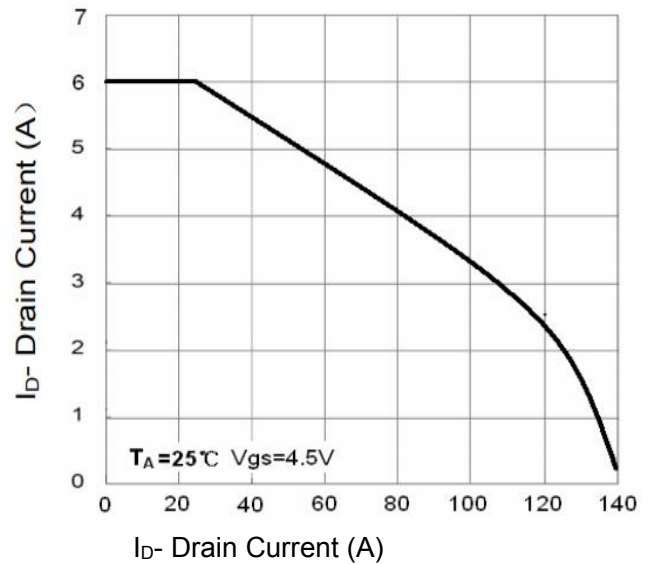
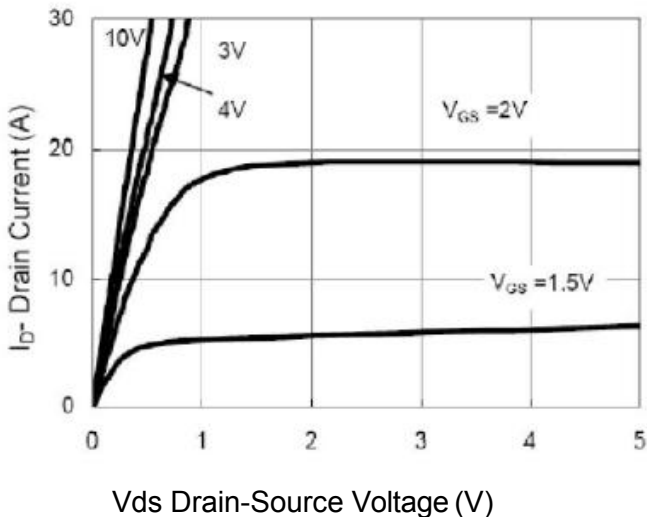
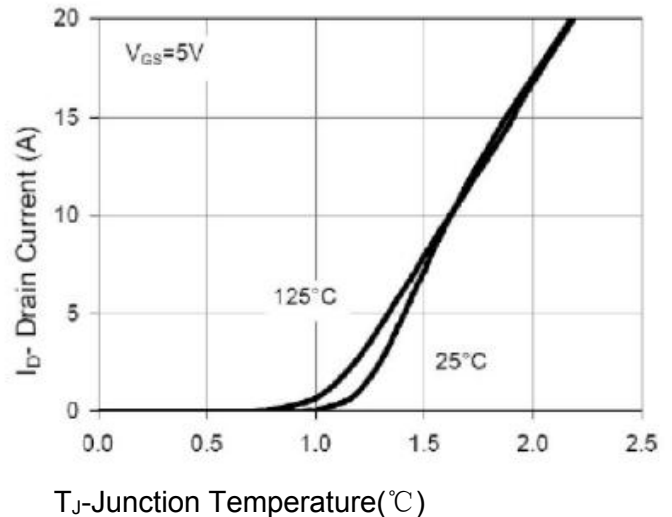
**TYPICAL ELECTRICAL AND THERMAL CHARACTERISTICS**

**Figure 1: Switching Test Circuit**

**Figure 2: Switching Waveforms**

**Figure 3 Power Dissipation**

**Figure 4 Drain-Source On-Resistance**

**Figure 5. Capacitance**

**Figure 6. R<sub>DS(on)</sub> vs Junction Temperature**

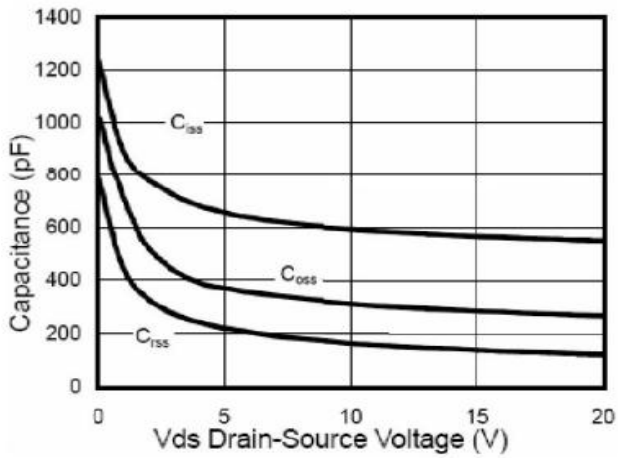

Figure7. Max  $V_{DSS}$  vs Junction Temperature

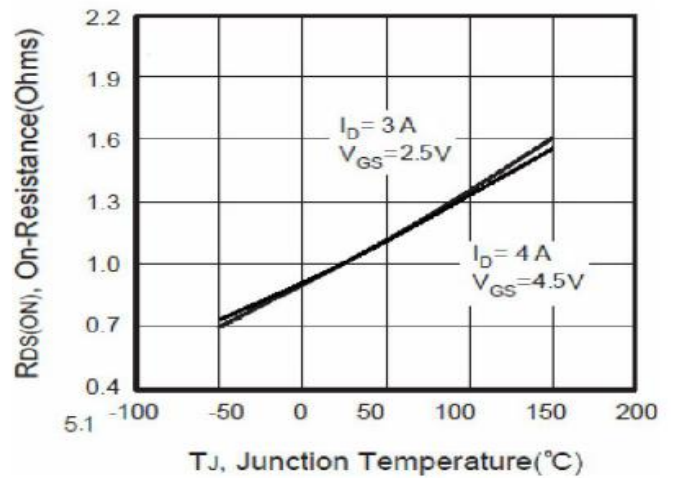

Figure8.  $V_{GS(th)}$  vs Junction Temperature

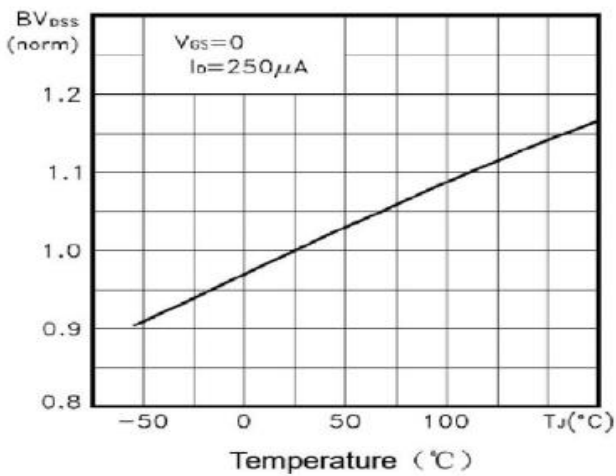

Figure9. Gate Charge Waveforme

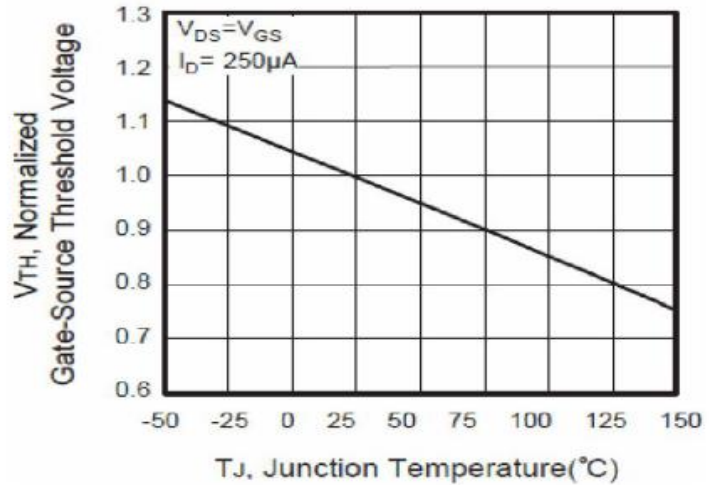

Figure10. Maximum Safe Operating Area

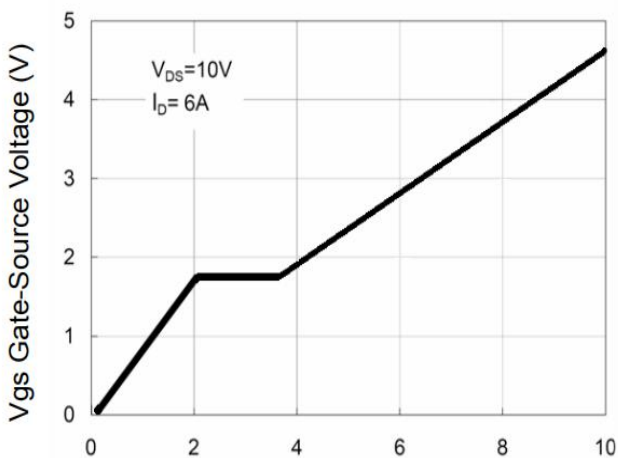

Figure 11 Gate Charge

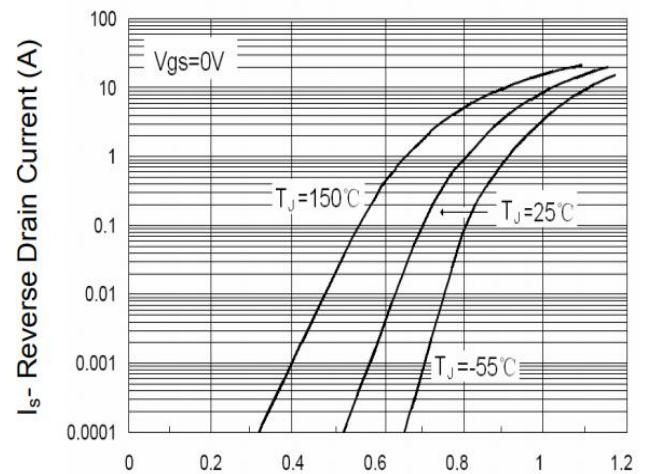
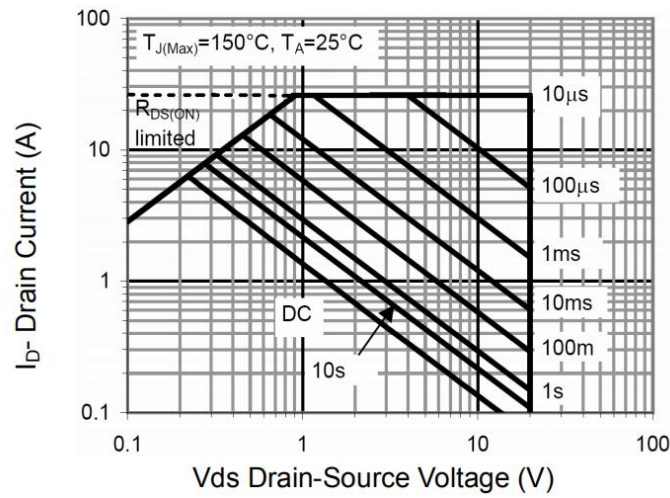
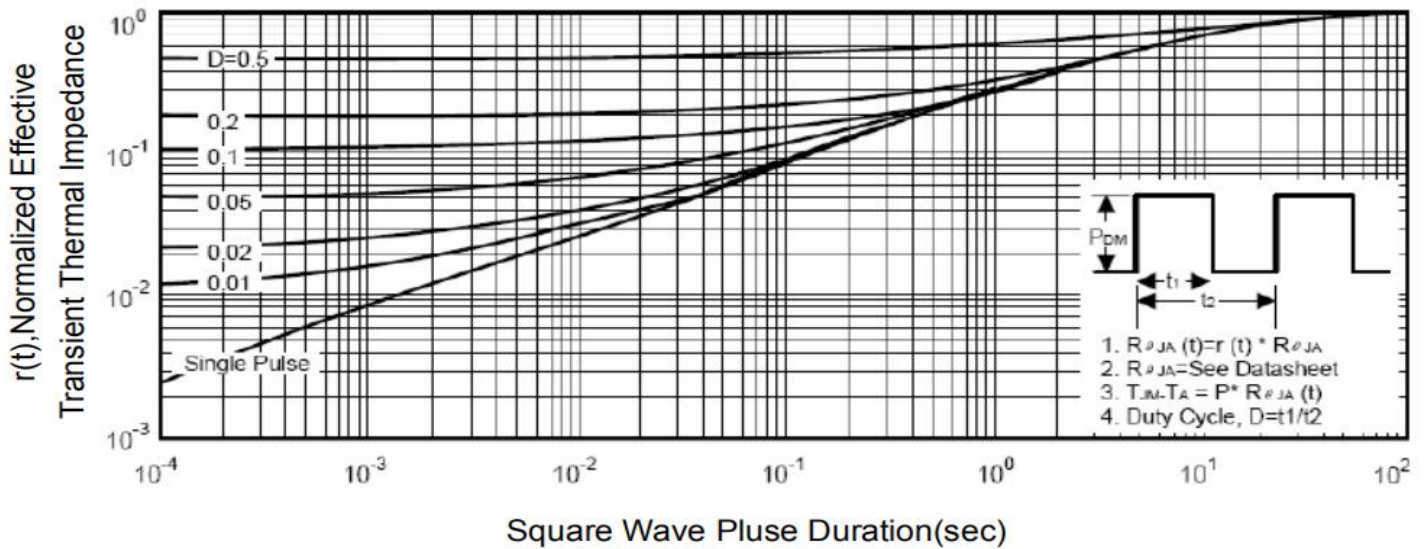
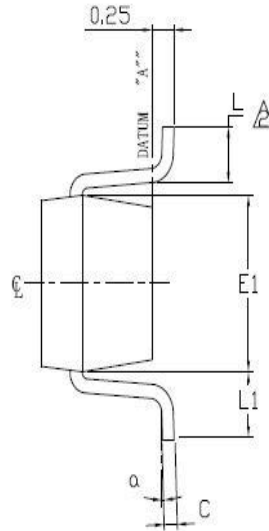
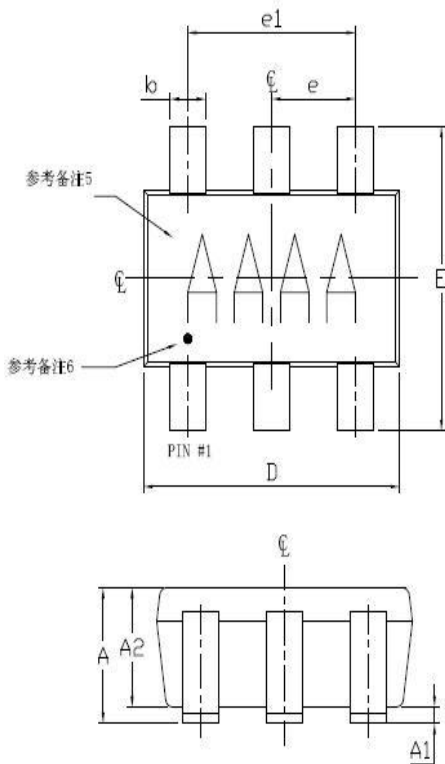

Figure 12 Safe Operation Area

**Figure 13 Safe Operation Area**

**Figure 14 Normalized Maximum Transient Thermal Impedance**

**SOT23-6 PACKAGE IN**

SYMBOL	MIN	NOM	MAX
A	0.90	1.25	1.45
A1	0.00	0.05	0.15
A2	0.90	1.10	1.30
b	0.35	0.40	0.50
C	0.08	0.15	0.20
D	2.80	2.90	3.00
E	2.60	2.80	3.00
E1	1.50	1.625	1.75
L	0.35	0.45	0.60
L1	0.60 REF.		
e1	1.90 BSC.		
e	0.95 BSC.		
a	0°	2.5°	8°

PKG CODES:  
U6-1, U6-2, U6-4, U6CN-2,  
U6SN-1, U6F-6, U6FH-6

**备注:**

1. 标注单位:MM.
2. 引脚长度的测量点为引脚与塑封体接触点及引脚边缘最长处。
3. 塑封体测量尺寸不包括毛刺及金属毛刺, 另塑封体毛刺及金属毛刺长度不超过0.25mm.
4. 引脚平面度控制小于0.1mm.
5. 印字面向上进行读取时, PIN1 位于左下方(参考图解).
6. PIN1的标记最小为 $\varnothing$ 0.3mm, 并位于PIN1脚位上方.
7. 考文献: JEDECT0236-VARIATION AB.