

## DESCRIPTION

The MX3117 uses advanced trench technology to provide excellent  $R_{DS(ON)}$  and low gate charge. It can be used in a wide variety of applications. It is ESD protected.

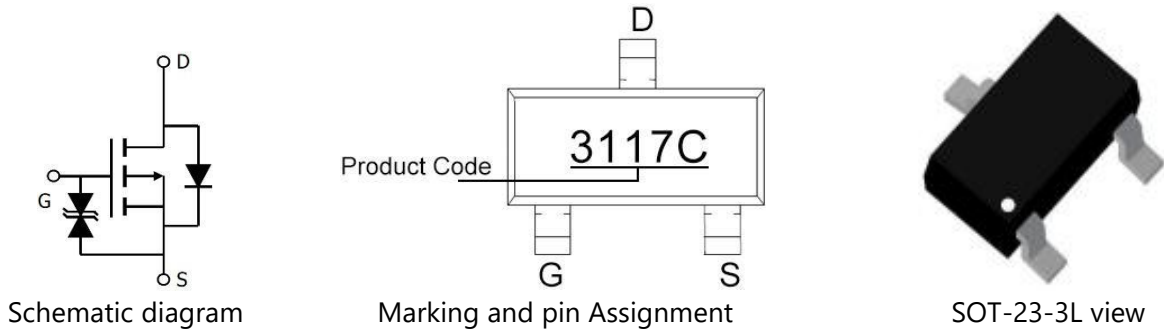
## GENERAL FEATURES

- $V_{DS}=-30V$ ,  $I_D=-7A$   
 $R_{DS(ON)}(Typ.)=23m\Omega$  @  $V_{GS}=-4.5V$   
 $R_{DS(ON)}(Typ.)=17m\Omega$  @  $V_{GS}=-10V$
- High Power and current handling capability
- Lead free product is acquired
- Surface Mount Package

## APPLICATION

- PWM applications
- Load switch
- Power management

## PINOUT



## ORDERING INFORMATION

Part Number	Marking	Storage Temperature	Package	Devices Per Reel
MX3117	3117C	-55°C to 150°C	SOT-23-3L	3000

## ABSOLUTE MAXIMUM RATINGS ( $T_A=25^\circ C$ unless otherwise noted)

Parameter	Symbol	Limit	Unit
Drain-Source Voltage	$V_{DS}$	-30	V
Gate-Source Voltage	$V_{GS}$	$\pm 20$	V
Drain Current-Continuous	$I_D$	-7	A
Drain Current-Pulsed <sup>(Note1)</sup>	$I_{DM}$	-18	A
Maximum Power Dissipation	$P_D$	29	W
Operating Junction and Storage Temperature Range	$T_J, T_{STG}$	-55 to 150	°C

## THERMAL RESISTANCE

Thermal Resistance, Junction-to-Ambient <sup>(Note2)</sup>	$R_{\theta JA}$	84	°C/W
------------------------------------------------------------	-----------------	----	------

Note 1. Repetitive Rating: Pulse width limited by maximum junction temperature.

Note 2. Surface Mounted on FR4 Board,  $t \leq 10$  sec.



**ELECTRICAL CHARACTERISTICS** ( $T_A=25^\circ\text{C}$  unless otherwise noted)

Parameter	Symbol	Conditions	Min	Typ	Max	Unit
-----------	--------	------------	-----	-----	-----	------

**Off Characteristics**

Drain-Source Breakdown Voltage	$BV_{DSS}$	$V_{GS}=0V, I_D=-250\mu A$	-30	-	-	V
Zero Gate Voltage Drain Current	$I_{DSS}$	$V_{DS}=-30V, V_{GS}=0V$	-	-	-1	$\mu A$
Gate-Body Leakage Current	$I_{GSS}$	$V_{GS}=\pm 20V, V_{DS}=0V$	-	-	$\pm 10$	$\mu A$

**On Characteristics** (Note3)

Gate Threshold Voltage	$V_{GS(th)}$	$V_{DS}=V_{GS}, I_D=-250\mu A$	-0.9	-1.5	-2.1	V
Drain-Source On-State Resistance	$R_{DS(ON)}$	$V_{GS}=-4.5V, I_D=-4A$	-	23	32	$m\Omega$
		$V_{GS}=-10V, I_D=-4.5A$	-	17	22	$m\Omega$
Forward Transconductance	$g_{FS}$	$V_{DS}=-10V, I_D=-4.1A$	20	-	-	S

**Dynamic Characteristics** (Note4)

Input Capacitance	$C_{iss}$	$V_{DS}=-15V, V_{GS}=0V, F=10KHz$	-	235	-	$pF$
Output Capacitance	$C_{oss}$		-	180	-	$pF$
Reverse Transfer Capacitance	$C_{rss}$		-	25	-	$pF$
Gate Resistance	$R_g$	$V_{DS}=0V, V_{GS}=0V, F=10KHz$	-	5	-	$k\Omega$

**Switching Characteristics** (Note4)

Turn-on Delay Time	$t_{d(on)}$	$V_{DS}=-15V, R_L=1\Omega, V_{GS}=-10V, R_G=3\Omega$	-	9	-	nS
Turn-on Rise Time	$t_r$		-	5	-	nS
Turn-Off Delay Time	$t_{d(off)}$		-	28	-	nS
Turn-Off Fall Time	$t_f$		-	13.8	-	nS
Total Gate Charge	$Q_g$	$V_{DS}=-15V, I_D=-4A, V_{GS}=-10V$	-	22	-	nC
Gate-Source Charge	$Q_{gs}$		-	3	-	nC
Gate-Drain Charge	$Q_{gd}$		-	7	-	nC

**Drain-Source Diode Characteristics**

Diode Forward Voltage (Note3)	$V_{SD}$	$V_{GS}=0V, I_S=-1A$	-	-	-1.2	V
Diode Forward Current (Note2)	$I_S$		-	-	-3	A

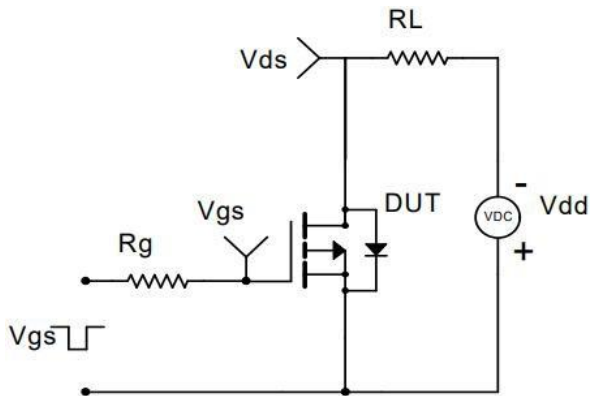
Note 2. Surface Mounted on FR4 Board,  $t \leq 10$  sec.

Note 3. Pulse Test: Pulse Width  $\leq 300\mu s$ , Duty Cycle  $\leq 2\%$ .

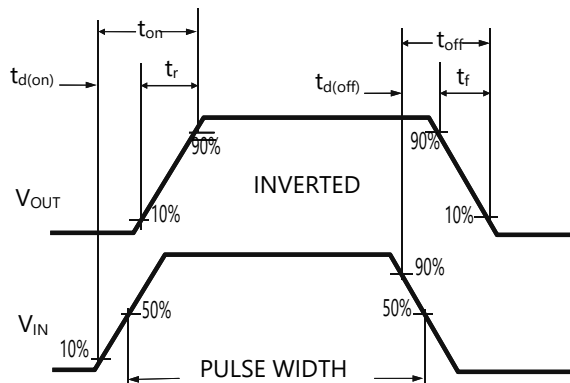
Note 4. Guaranteed by design, not subject to production

**TYPICAL ELECTRICAL AND THERMAL CHARACTERISTICS**

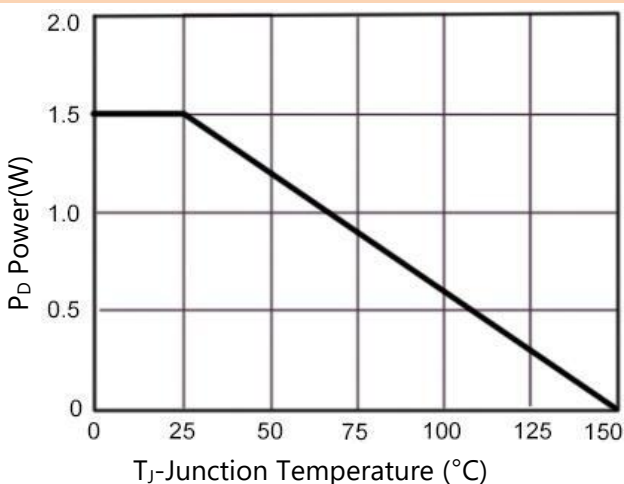
**Figure 1. Switching Test Circuit**



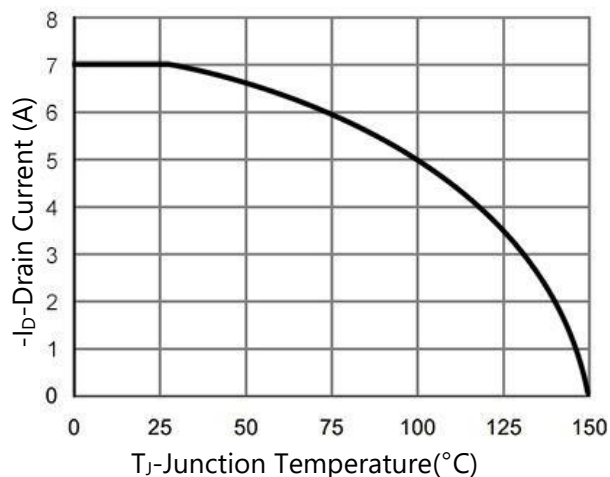
**Figure 2. Switching Waveform**



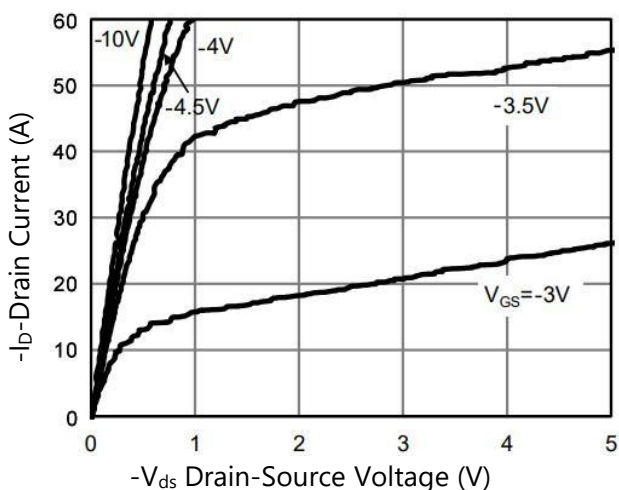
**Figure 3. Power De-rating**



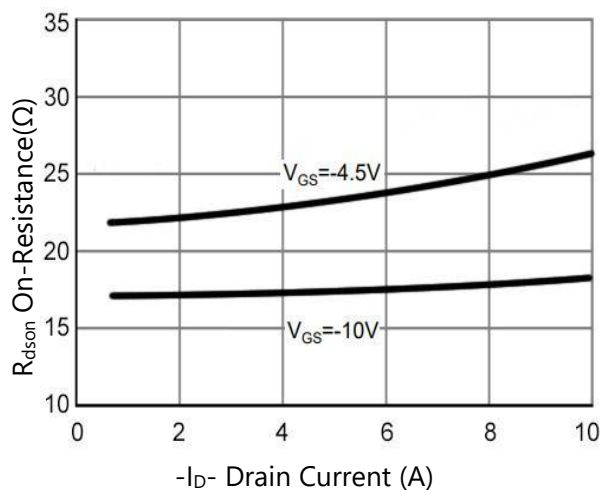
**Figure 4. Drain Current**



**Figure 5. Output Characteristics**



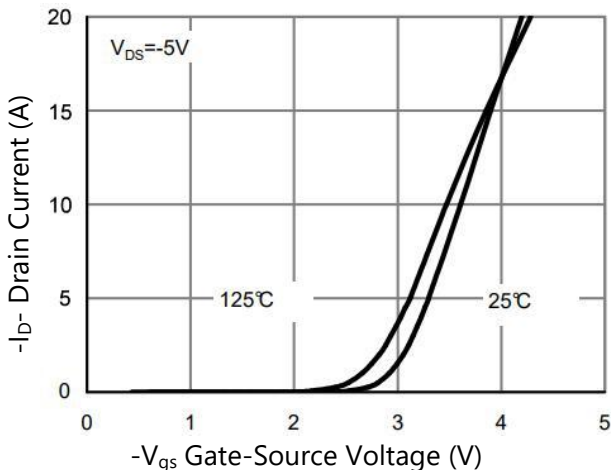
**Figure 6. R<sub>dson</sub> vs Drain Current**



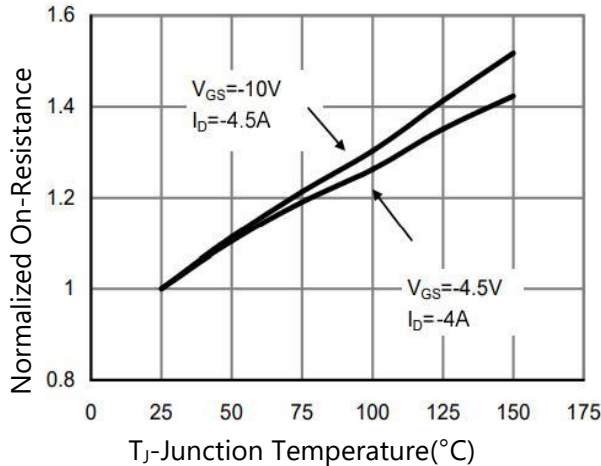


**TYPICAL ELECTRICAL AND THERMAL CHARACTERISTICS**

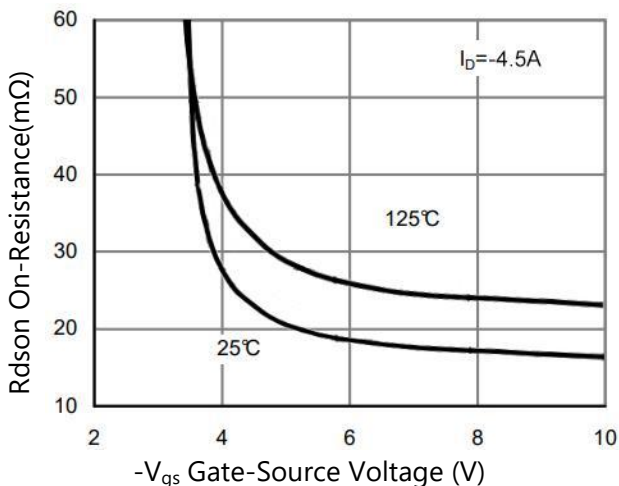
**Figure 7. Transfer Characteristics**



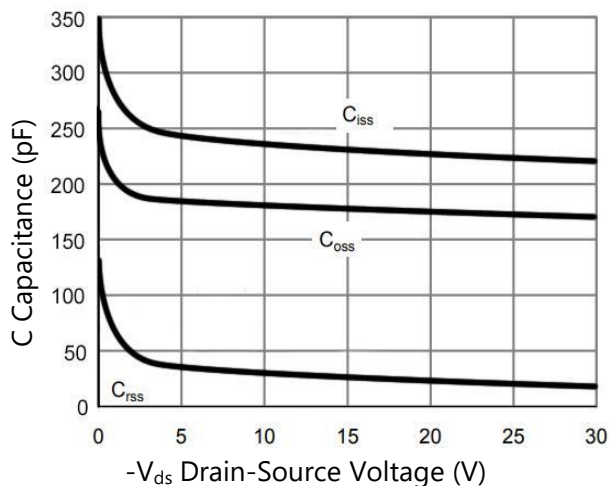
**Figure 8.  $R_{dson}$  vs Junction Temperature**



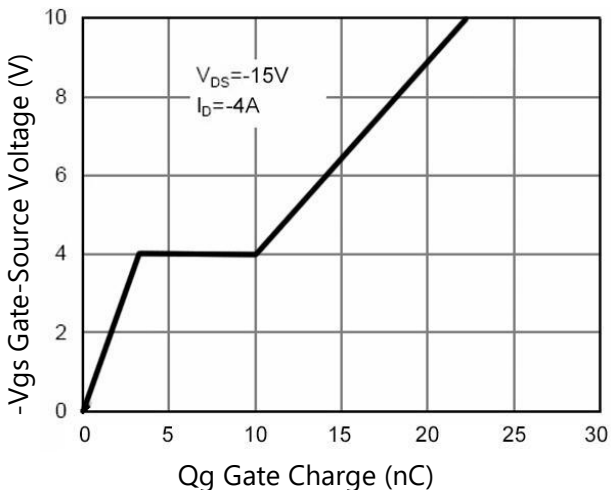
**Figure 9.  $R_{dson}$  vs  $V_{GS}$**



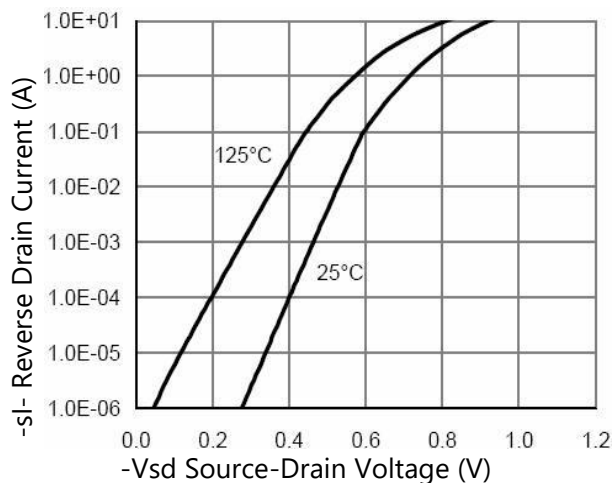
**Figure 10. Capacitance vs  $V_{ds}$**



**Figure 11. Gate Charge**

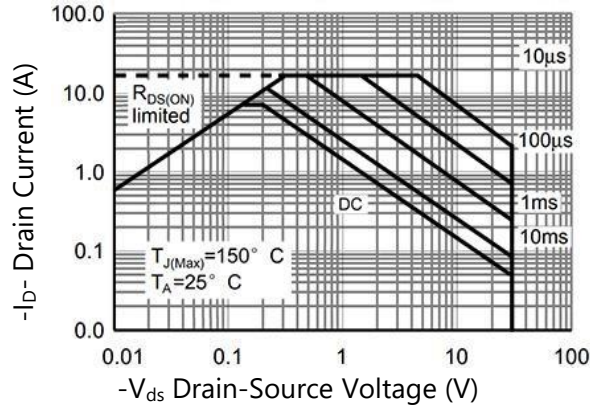


**Figure 12. Source- Drain Diode Forward**

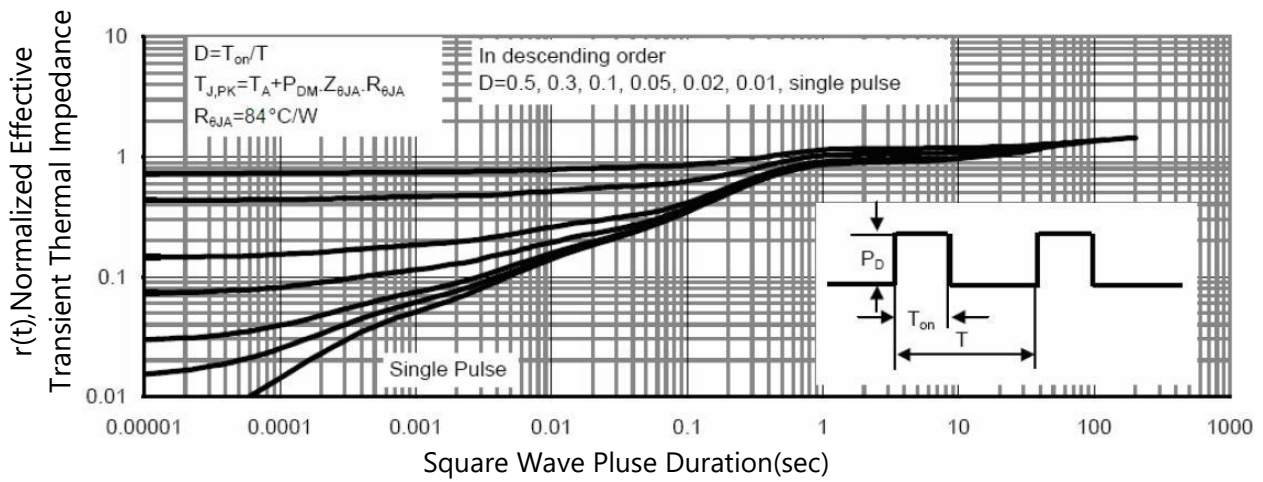


**TYPICAL ELECTRICAL AND THERMAL CHARACTERISTICS**

**Figure 11. Safe Operation Area**

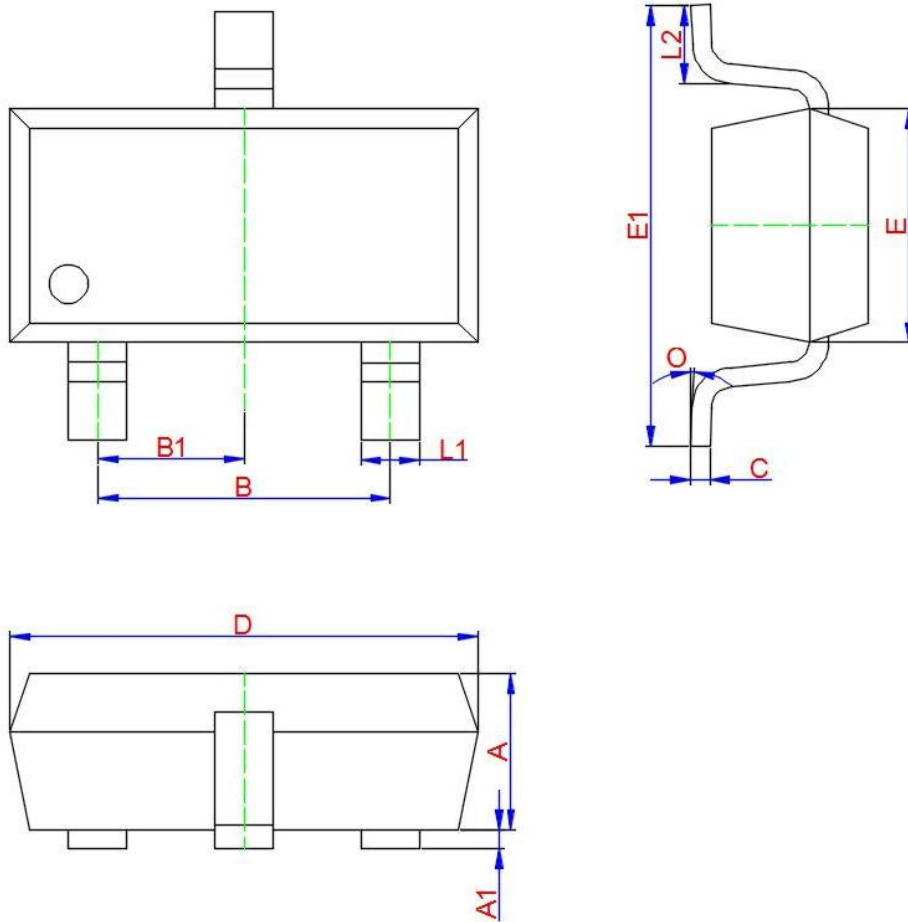


**Figure 12. Normalized Maximum Transient Thermal Impedance**



PACKAGE INFORMATION

SOT-23-3L



Symbol	Dimensions In Millimeters		
	Min.	Typ.	Max.
A	1.050	1.100	1.150
A1	0.000	0.050	0.100
L1	0.300	0.400	0.500
C	0.100	0.150	0.200
D	2.820	2.920	3.020
E	1.500	1.600	1.700
E1	2.650	2.800	2.950
B	1.800	1.900	2.000
B1	0.950 TYP.		
L2	0.300	0.450	0.600
O	0°	4°	8°