

DESCRIPTION

The MX6058 uses advanced trench technology to provide excellent $R_{DS(ON)}$ and low gate charge. It can be used in a wide variety of applications.

GENERAL FEATURES

- $V_{DS}=60V$, $I_D=10A$
 $R_{DS(ON)}(Typ.)=12.5m\Omega @ V_{GS}=4.5V$
 $R_{DS(ON)}(Typ.)=11m\Omega @ V_{GS}=10V$
- High Power and current handling capability
- Lead free product is acquired
- Surface Mount Package

APPLICATION

- PWM applications
- Load switch
- Power management

PINOUT

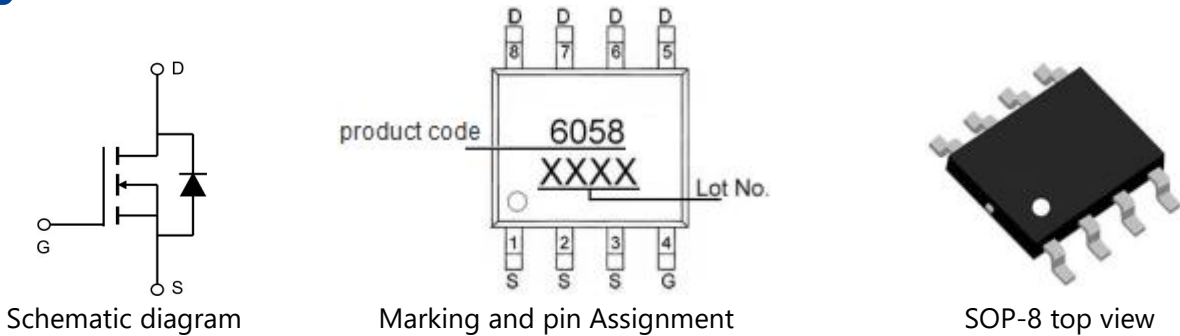

Schematic diagram

Marking and pin Assignment

SOP-8 top view

ORDERING INFORMATION

| Part Number | Storage Temperature | Package | Devices Per Reel |
|-------------|---------------------|---------|------------------|
| MX6058 | -55°C to 150°C | SOP-8 | - |

ABSOLUTE MAXIMUM RATINGS ($T_A=25^\circ C$ unless otherwise noted)

| Parameter | Symbol | Limit | Unit |
|--|----------------|------------|------------|
| Drain-Source Voltage | V_{DS} | 60 | V |
| Gate-Source Voltage | V_{GS} | ± 20 | V |
| Drain Current-Continuous | I_D | 10 | A |
| Drain Current-Continuous ($T_A=70^\circ C$) | I_D | 7.7 | A |
| Pulsed Drain Current ^(Note1) | I_{DM} | 40 | A |
| Maximum Power Dissipation | P_D | 3.1 | W |
| Operating Junction and Storage Temperature Range | T_J, T_{STG} | -55 to 150 | $^\circ C$ |

THERMAL RESISTANCE

| | | | |
|--|-----------------|----|--------------|
| Thermal Resistance, Junction-to-Ambient ^(Note2) | $R_{\theta JA}$ | 40 | $^\circ C/W$ |
|--|-----------------|----|--------------|

Note 1. Repetitive Rating: Pulse width limited by maximum junction temperature.

Note 2. Surface Mounted on FR4 Board, $t \leq 10$ sec.

ELECTRICAL CHARACTERISTICS ($T_A=25^\circ\text{C}$ unless otherwise noted)

| Parameter | Symbol | Conditions | Min | Typ | Max | Unit |
|-----------|--------|------------|-----|-----|-----|------|
|-----------|--------|------------|-----|-----|-----|------|

Off Characteristics

| | | | | | | |
|---------------------------------|------------|-----------------------------|---|----|-----------|---------|
| Drain-Source Breakdown Voltage | BV_{DSS} | $V_{GS}=0V, I_D=250\mu A$ | - | 60 | - | V |
| Zero Gate Voltage Drain Current | I_{DSS} | $V_{DS}=53V, V_{GS}=0V$ | - | - | 1 | μA |
| Gate-Body Leakage Current | I_{GSS} | $V_{GS}=\pm 20V, V_{DS}=0V$ | - | - | ± 100 | nA |

On Characteristics (Note2)

| | | | | | | |
|----------------------------------|--------------|-------------------------------|-----|------|-----|------------|
| Gate Threshold Voltage | $V_{GS(th)}$ | $V_{DS}=V_{GS}, I_D=250\mu A$ | 1.2 | 2 | 2.5 | V |
| Drain-Source On-State Resistance | $R_{DS(ON)}$ | $V_{GS}=4.5V, I_D=7A$ | - | 12.5 | 20 | m Ω |
| | | $V_{GS}=10V, I_D=8A$ | - | 11 | 16 | m Ω |
| Forward Transconductance | g_{FS} | $V_{DS}=5V, I_D=8A$ | - | 33 | - | S |

Dynamic Characteristics (Note3)

| | | | | | | |
|------------------------------|-----------|-----------------------------------|---|------|---|----|
| Input Capacitance | C_{iss} | $V_{DS}=30V, V_{GS}=0V, F=1.0MHz$ | - | 2245 | - | pF |
| Output Capacitance | C_{oss} | | - | 135 | - | pF |
| Reverse Transfer Capacitance | C_{rss} | | - | 100 | - | pF |

Switching Characteristics

| | | | | | | |
|---------------------|--------------|--|---|------|---|----|
| Turn-on Delay Time | $t_{d(on)}$ | $V_{DS}=30V, R_L=1\Omega, V_{GS}=10V, R_G=3\Omega$ | - | 5 | - | nS |
| Turn-on Rise Time | t_r | | - | 3 | - | nS |
| Turn-Off Delay Time | $t_{d(off)}$ | | - | 19 | - | nS |
| Turn-Off Fall Time | t_f | | - | 3 | - | nS |
| Total Gate Charge | Q_g | $V_{DS}=30V, I_D=8A, V_{GS}=10V$ | - | 13.5 | - | nC |
| Gate-Source Charge | Q_{gs} | | - | 2.5 | - | nC |
| Gate-Drain Charge | Q_{gd} | | - | 3 | - | nC |

Drain-Source Diode Characteristics

| | | | | | | |
|-------------------------------|----------|---------------------|---|---|-----|---|
| Diode Forward Voltage (Note2) | V_{SD} | $V_{GS}=0V, I_S=1A$ | - | - | 1.2 | V |
| Diode Forward Current (Note1) | I_S | | - | - | 4 | A |

Note 1. Surface Mounted on FR4 Board, $t \leq 10$ sec.

Note 2. Pulse Test: Pulse Width $\leq 300\mu s$, Duty Cycle $\leq 2\%$.

Note 3. Guaranteed by design, not subject to product.

TYPICAL ELECTRICAL AND THERMAL CHARACTERISTICS

Figure 1. Switching Test Circuit

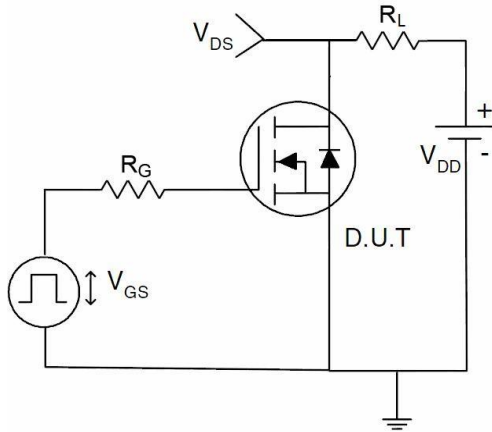

Figure 2. Switching Waveform

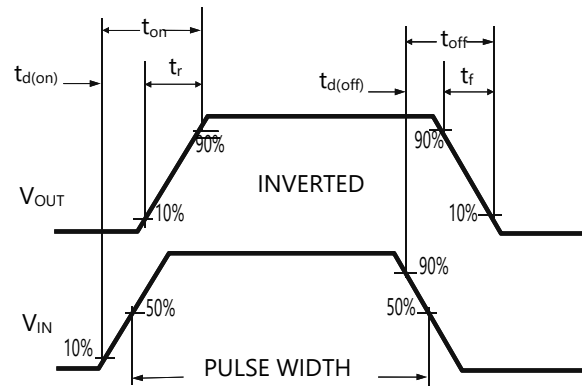

Figure 3. Power Dissipation

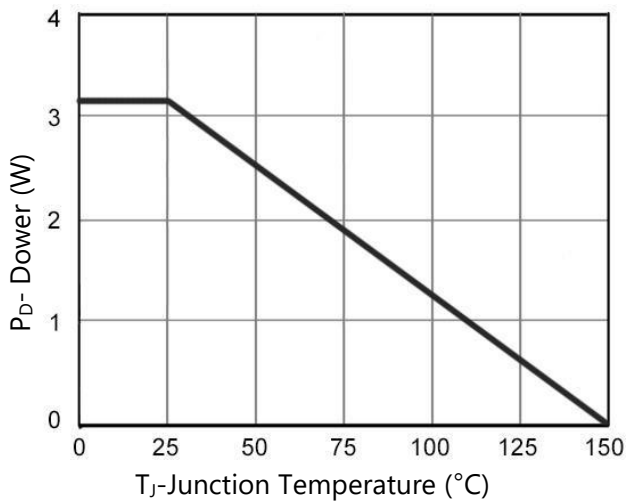

Figure 4. Drain Current

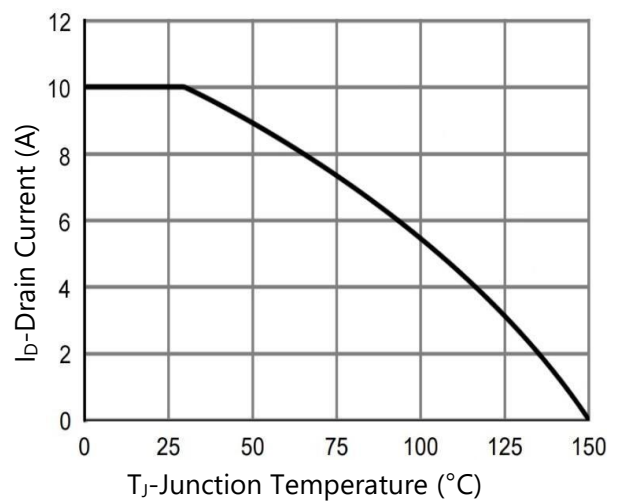

Figure 5. Output Characteristics

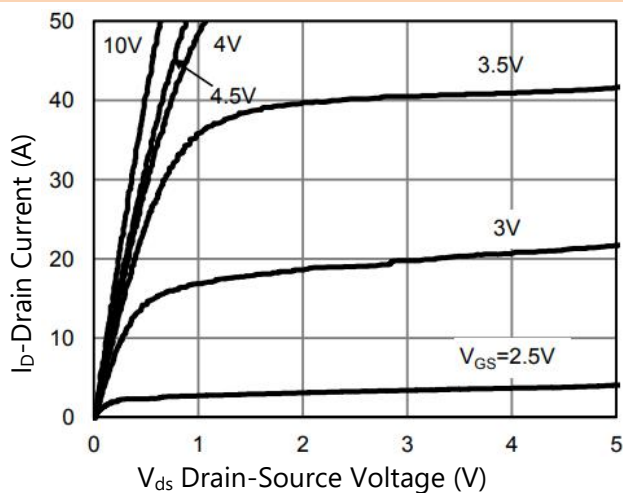
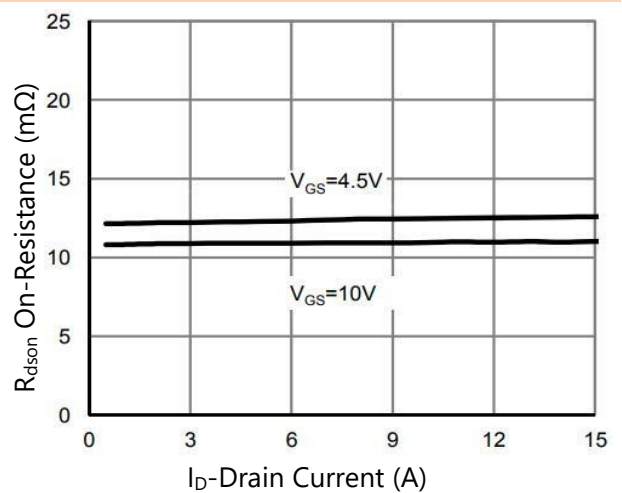

Figure 6. R_{ds(on)} vs Drain Current





TYPICAL ELECTRICAL AND THERMAL CHARACTERISTICS

Figure 7. Transfer Characteristics

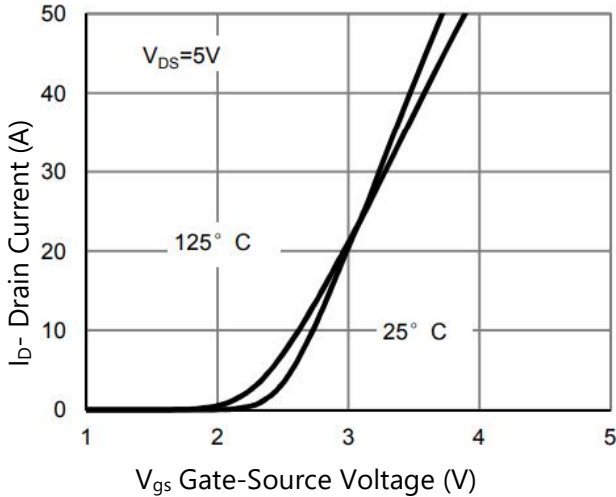

Figure 8. R_{dson} vs Junction Temperature

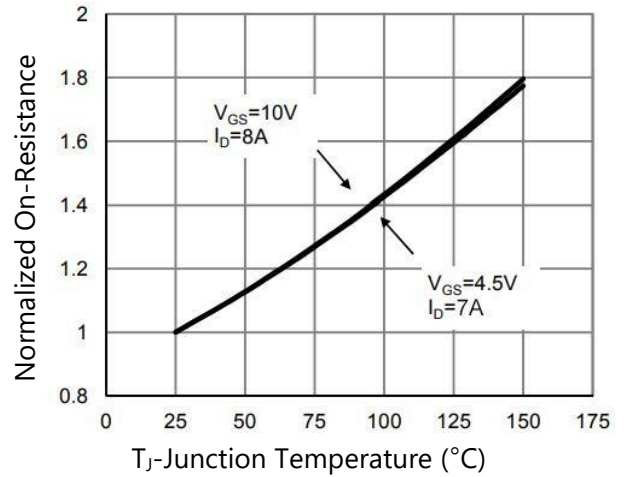

Figure 9. R_{dson} vs V_{GS}

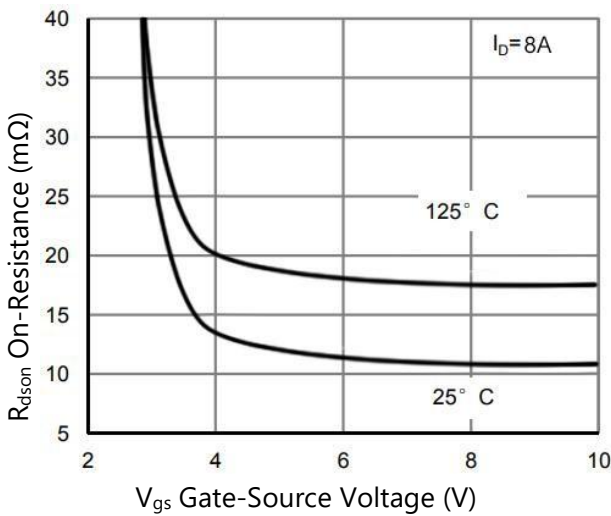

Figure 10. Capacitance vs V_{DS}

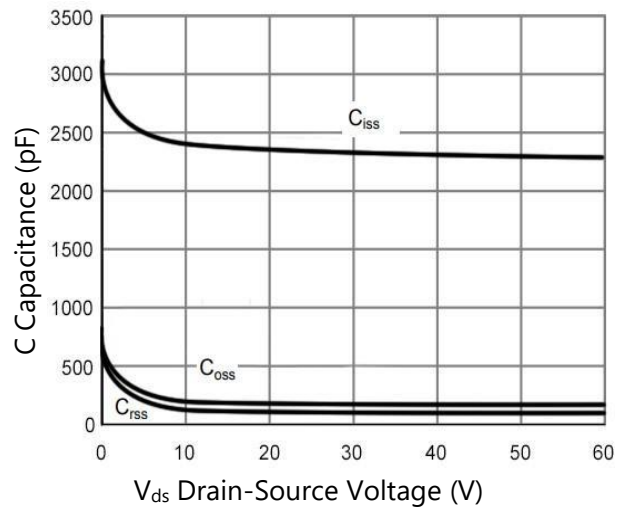

Figure 11. Gate Charge

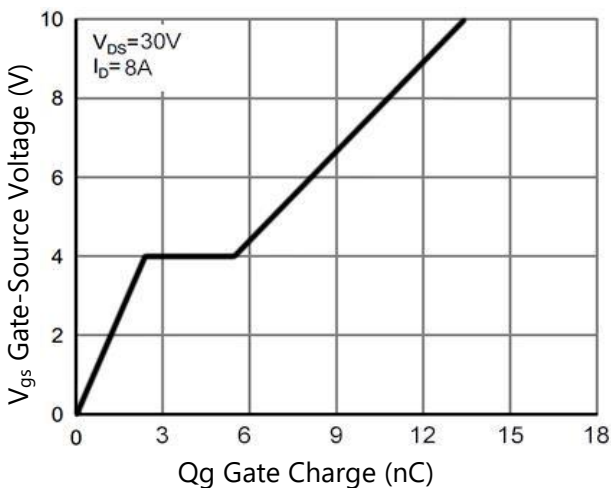
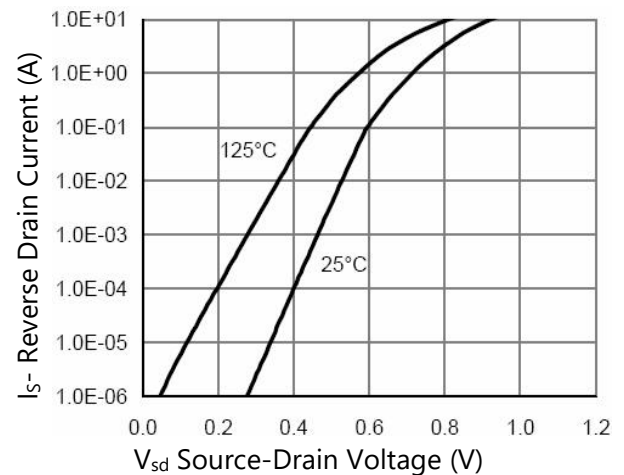

Figure 12. Source- Drain Diode Forward



TYPICAL ELECTRICAL AND THERMAL CHARACTERISTICS

Figure 13. Safe Operation Area

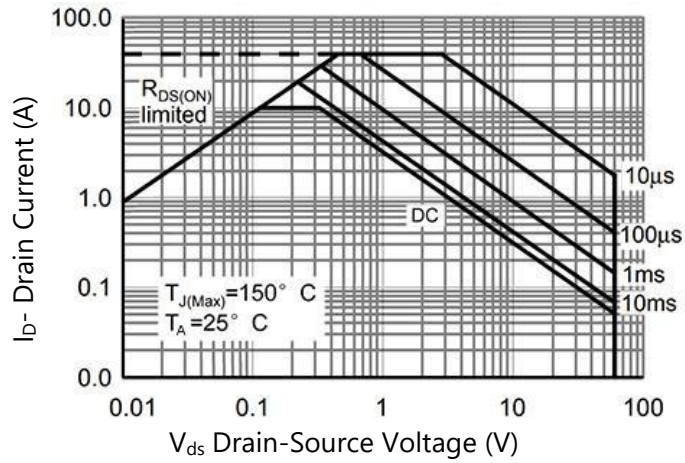
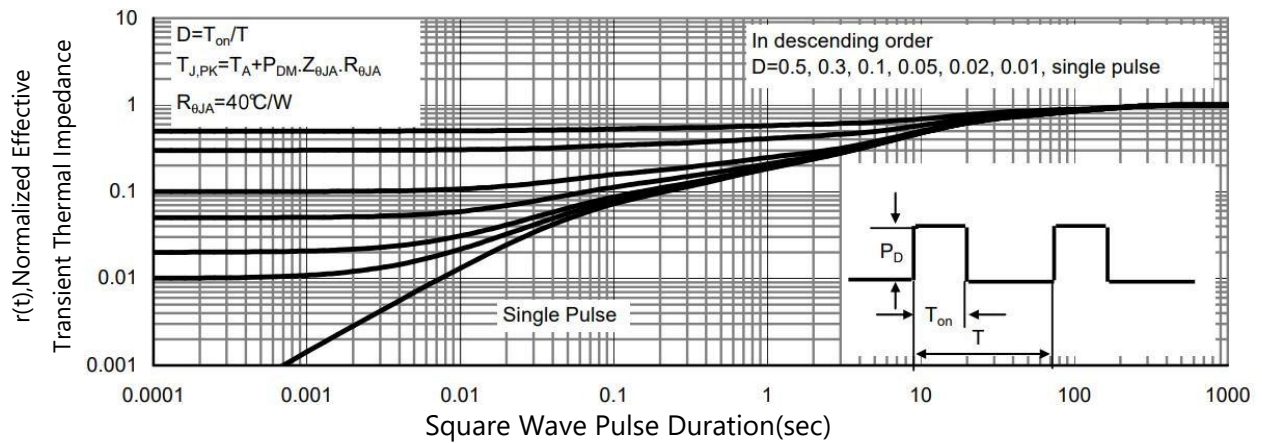
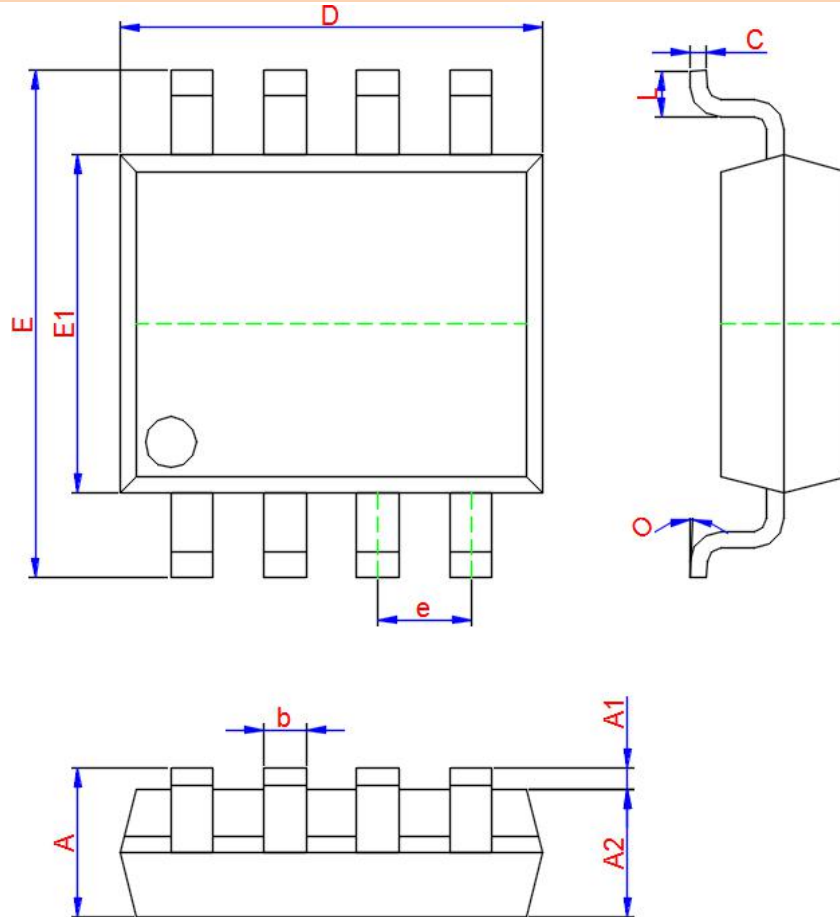

Figure 14. Normalized Maximum Transient Thermal Impedance



PACKAGE INFORMATION

SOP-8



| Symbol | Dimensions in Millimeters | | |
|--------|---------------------------|-------|-------|
| | Min. | Typ. | Max. |
| A | 1.350 | 1.550 | 1.750 |
| A1 | 0.100 | 0.175 | 0.250 |
| A2 | 1.350 | 1.450 | 1.550 |
| b | 0.330 | 0.420 | 0.510 |
| c | 0.170 | 0.210 | 0.250 |
| D | 4.700 | 4.900 | 5.100 |
| e | 1.270 TYP. | | |
| E | 5.800 | 6.000 | 6.200 |
| E1 | 3.750 | 3.900 | 4.050 |
| L | 0.400 | 0.835 | 1.270 |
| O | 0° | 4° | 8° |