

## DESCRIPTION

The MXD30N100 uses advanced trench technology to provide excellent  $R_{DS(ON)}$  and low gate charge. It can be used in a wide variety of applications.

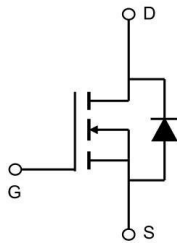
## GENERAL FEATURES

- $V_{DS}=30V$ ,  $I_D=100A$   
 $R_{DS(ON)}(Typ.)=5.5m\Omega$  @  $V_{GS}=4.5V$   
 $R_{DS(ON)}(Typ.)=4.3m\Omega$  @  $V_{GS}=10V$
- High Power and current handling capability
- Lead free product is acquired
- Surface Mount Package

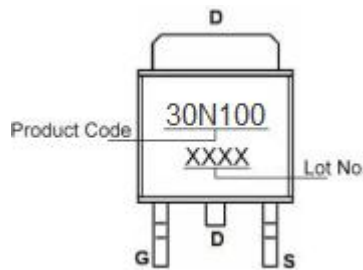
## APPLICATION

- Battery management
- Motor controller and driver
- PWM applications
- Load switch

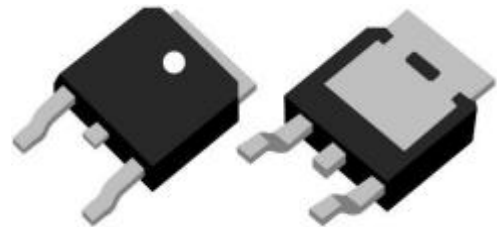
## PINOUT



Schematic diagram



Marking and pin Assignment



TO-252-2L top & bottom view

## ORDERING INFORMATION

Part Number	Storage Temperature	Package	Devices Per Reel
MX30N100	-55°C to 175°C	TO-252-2L	-

## ABSOLUTE MAXIMUM RATINGS ( $T_C=25^\circ C$ unless otherwise noted)

Parameter	Symbol	Limit	Unit
Drain-Source Voltage	$V_{DS}$	30	V
Gate-Source Voltage	$V_{GS}$	$\pm 20$	V
Drain Current-Continuous	$I_D$	100	A
Drain Current-Continuous ( $T_C=100^\circ C$ )	$I_D$	70	A
Pulsed Drain Current <sup>(Note1)</sup>	$I_{DM}$	350	A
Maximum Power Dissipation	$P_D$	110	W
Single Pulse Avalanche Energy ( $L=0.5mH$ )	$E_{AS}$	298	mJ
Operating Junction and Storage Temperature Range	$T_J, T_{STG}$	-55 to 175	$^\circ C$

## THERMAL RESISTANCE

Thermal Resistance, Junction-to-Case <sup>(Note2)</sup>	$R_{\theta JC}$	1.36	$^\circ C/W$
---	-----------------	------	--------------

Note 1. Repetitive Rating: Pulse width limited by maximum junction temperature.

Note 2. Surface Mounted on FR4 Board,  $t \leq 10$  sec.



**ELECTRICAL CHARACTERISTICS** ( $T_C=25^\circ\text{C}$  unless otherwise noted)

Parameter	Symbol	Conditions	Min	Typ	Max	Unit
-----------	--------	------------	-----	-----	-----	------

**Off Characteristics**

Drain-Source Breakdown Voltage	$BV_{DSS}$	$V_{GS}=0V, I_D=250\mu A$	30	-	-	V
Zero Gate Voltage Drain Current	$I_{DSS}$	$V_{DS}=30V, V_{GS}=0V$	-	-	1	$\mu A$
Gate-Body Leakage Current	$I_{GSS}$	$V_{GS}=\pm 20V, V_{DS}=0V$	-	-	$\pm 100$	nA

**On Characteristics** (Note2)

Gate Threshold Voltage	$V_{GS(th)}$	$V_{DS}=V_{GS}, I_D=250\mu A$	1.0	1.6	2.5	V
Drain-Source On-State Resistance	$R_{DS(ON)}$	$V_{GS}=4.5V, I_D=30A$	-	5.5	7	m $\Omega$
		$V_{GS}=10V, I_D=30A$	-	4.3	5.5	m $\Omega$
Forward Transconductance	$g_{FS}$	$V_{DS}=5V, I_D=20A$	-	90	-	S

**Dynamic Characteristics** (Note3)

Input Capacitance	$C_{iss}$	$V_{DS}=15V, V_{GS}=0V, F=1.0MHz$	-	2640	-	pF
Output Capacitance	$C_{oss}$		-	260	-	pF
Reverse Transfer Capacitance	$C_{rss}$		-	220	-	pF
Gate Resistance	$R_g$	$V_{DS}=0V, V_{GS}=0V, F=1.0MHz$	-	7	-	$\Omega$

**Switching Characteristics**

Turn-on Delay Time	$t_{d(on)}$	$V_{DS}=15V, I_D=2A, R_L=1\Omega, V_{GS}=10V, R_G=3\Omega$	-	7.3	-	nS
Turn-on Rise Time	$t_r$		-	11	-	nS
Turn-Off Delay Time	$t_{d(off)}$		-	22	-	nS
Turn-Off Fall Time	$t_f$		-	5	-	nS
Total Gate Charge	$Q_g$	$V_{DS}=10V, I_D=20A, V_{GS}=10V$	-	54	-	nC
Gate-Source Charge	$Q_{gs}$		-	4.5	-	nC
Gate-Drain Charge	$Q_{gd}$		-	11	-	nC

**Drain-Source Diode Characteristics**

Diode Forward Voltage (Note2)	$V_{SD}$	$V_{GS}=0V, I_S=1A$	-	-	1.2	V
Diode Forward Current (Note1)	$I_S$		-	-	45	A

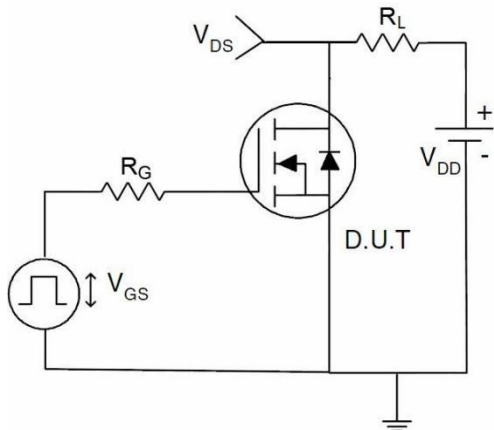
Note 1. Surface Mounted on FR4 Board,  $t \leq 10$  sec.

Note 2. Pulse Test: Pulse Width  $\leq 300\mu s$ , Duty Cycle  $\leq 2\%$ .

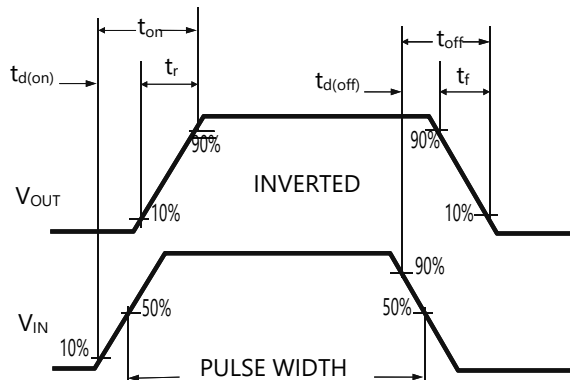
Note 3. Guaranteed by design, not subject to product.

**TYPICAL ELECTRICAL AND THERMAL CHARACTERISTICS**

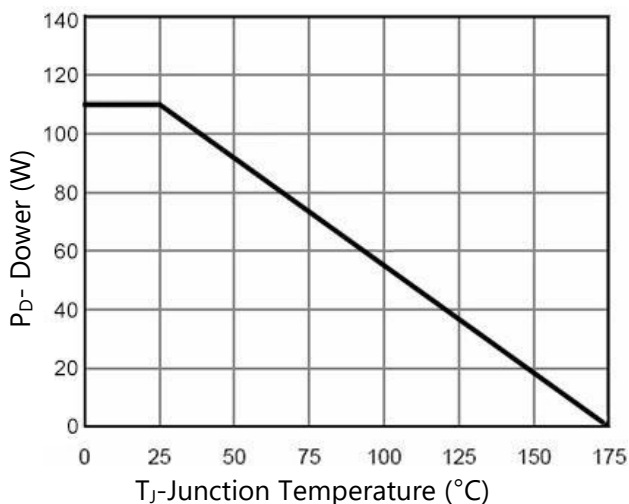
**Figure 1. Switching Test Circuit**



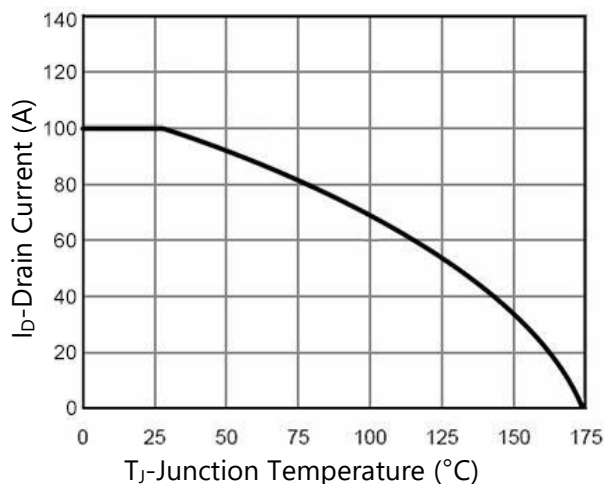
**Figure 2. Switching Waveform**



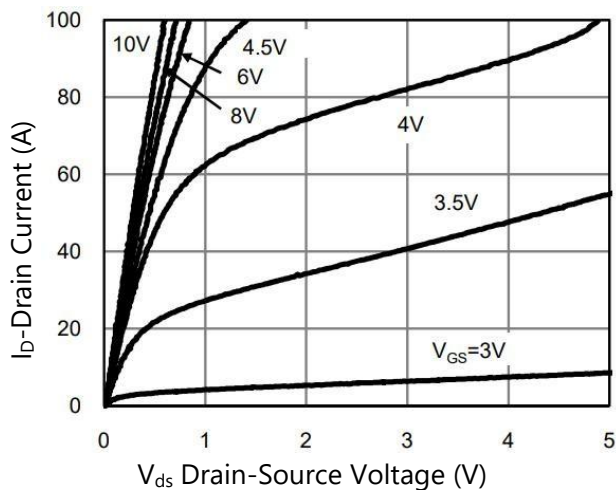
**Figure 3. Power Dissipation**



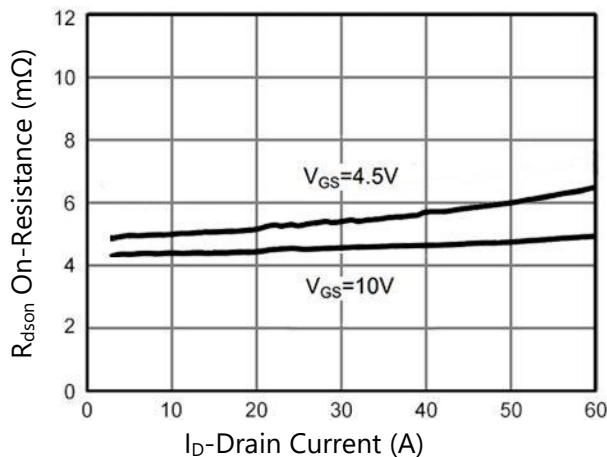
**Figure 4. Drain Current**



**Figure 5. Output Characteristics**



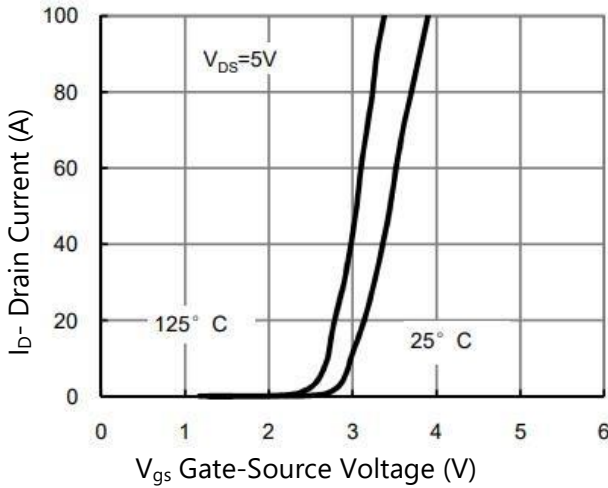
**Figure 6. R<sub>dson</sub> vs Drain Current**



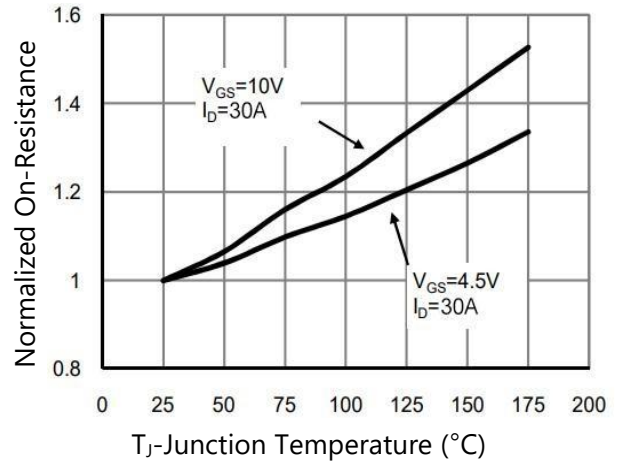


**TYPICAL ELECTRICAL AND THERMAL CHARACTERISTICS**

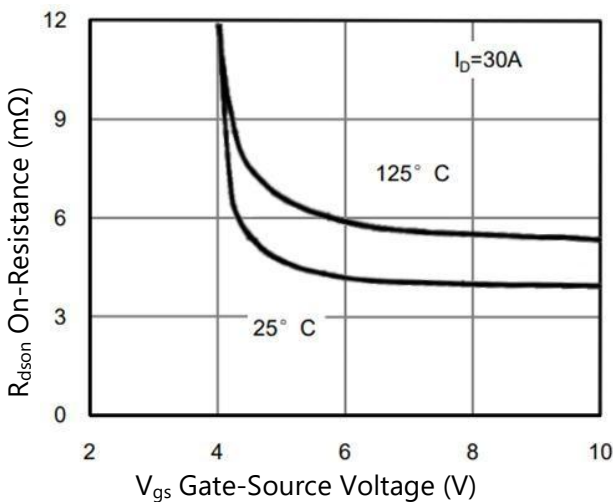
**Figure 7. Transfer Characteristics**



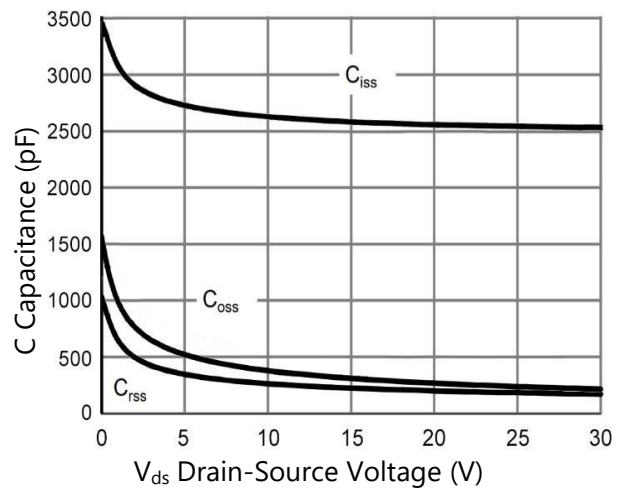
**Figure 8. R<sub>dson</sub> vs Junction Temperature**



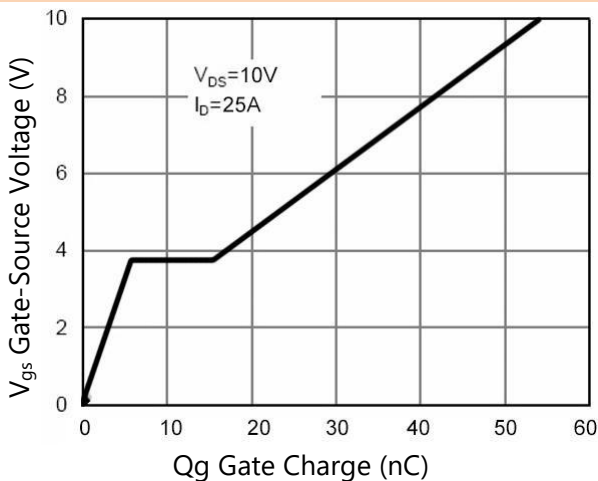
**Figure 9. R<sub>dson</sub> vs V<sub>GS</sub>**



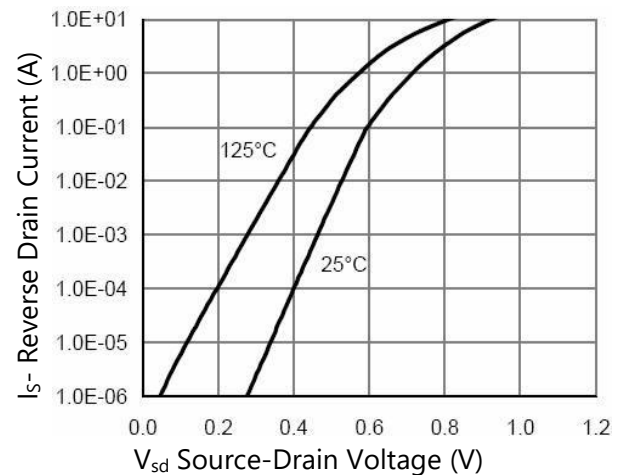
**Figure 10. Capacitance vs V<sub>DS</sub>**



**Figure 11. Gate Charge**

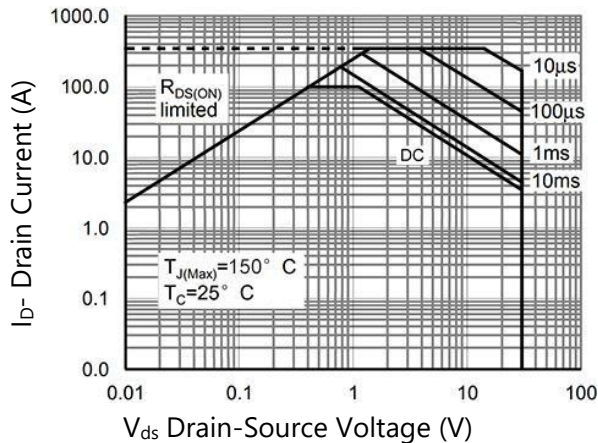


**Figure 12. Source- Drain Diode Forward**

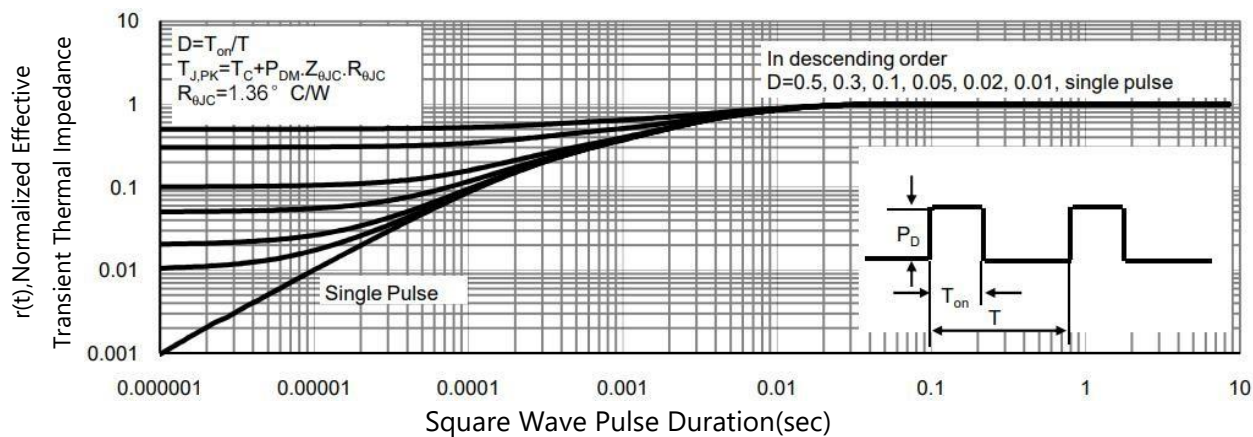


**TYPICAL ELECTRICAL AND THERMAL CHARACTERISTICS**

**Figure 13. Safe Operation Area**

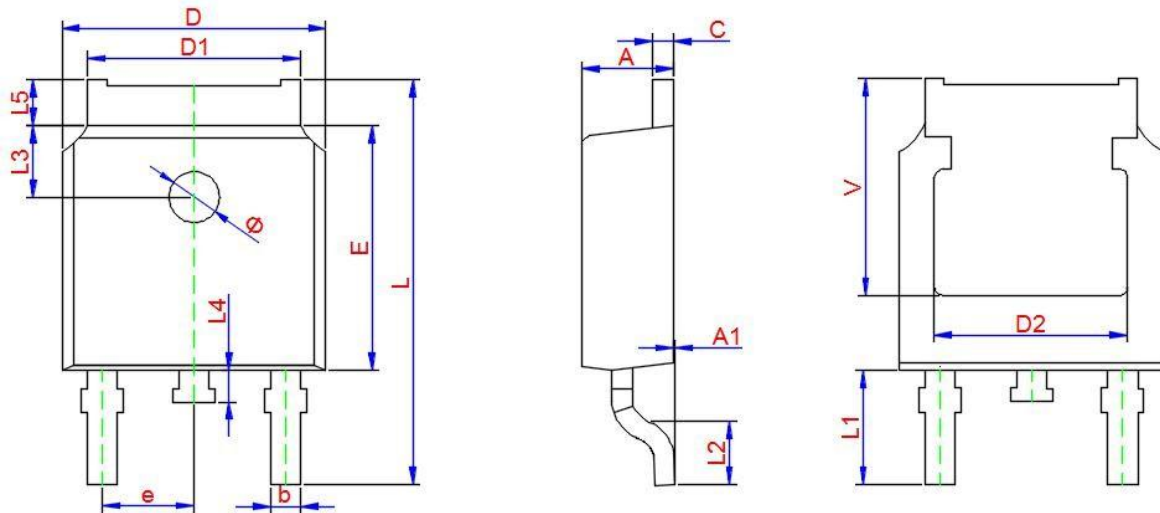


**Figure 14. Normalized Maximum Transient Thermal Impedance**



 **PACKAGE INFORMATION**

TO-252-2L



Symbol	Dimensions in Millimeters		
	Min.	Typ.	Max.
A	2.200	2.300	2.400
A1	0.000	-	0.127
D	6.500	6.600	6.700
D1	5.100	5.330	5.460
C	0.450	0.500	0.600
D2	4.830 TYP.		
E	6.000	6.100	6.200
e	2.186	2.286	2.386
L	9.800	10.100	10.400
L1	2.900 TYP.		
L2	1.400	1.500	1.600
L3	1.800 TYP.		
L4	0.600	0.800	1.000
L5	0.900	-	1.250
Φ	1.100.	-	1.300
θ	0°	-	8°
V	5.350		